



3 Años

MÓDULO DE

Matemática





BIENVENIDOS AL MARAVILLOSO MUNDO DEL APRENDIZAJE

Queridos estudiantes:

Con mucha alegría damos inicio a nuestros módulos de trabajo, para los niños y niñas de 3 años. En esta nueva etapa, cada descubrimiento es una aventura, y cada juego es una oportunidad para aprender.

A lo largo de este módulo, los niños y niñas explorarán, crearán, cantarán, jugarán y compartirán momentos llenos de magia. Las actividades están diseñadas para estimular su curiosidad, desarrollar habilidades motrices, emocionales, sociales y del lenguaje, siempre respetando su ritmo de aprendizaje y necesidades.

Nuestro principal objetivo es acompañar a cada niño en su crecimiento con amor, paciencia y alegría, creando un ambiente seguro donde se sientan valorados, felices y motivados a aprender.

"Todo por amor, nada por la fuerza"



ÍNDICE

Caratula	1
Bienvenida.....	2
Índice	3
Color rojo	4 -5
Círculo	6 - 8
Arriba – abajo	9 – 10
Dentro – fuera	11 -12
Color azul	13-14
Grande – pequeño	15-16
Encima – debajo	17-18
Alto – bajo	19-20
Abierto – cerrado	21-22
Cuadrado	23 -24
Color amarillo	25-26
Juntos – separados	27-28
Delante – detrás	29-30
Muchos- pocos	31-32
los números	33
Numero 1	34-45
Numero 2	46-53
El triángulo	54-55
Largo – corto.....	56
Conjunto	57
El número 3	59-69
Lleno – vacío	70-72
El numero 4	73-75
Cerca- lejos	76
Delgado – grueso	77
El número 5	78-79
Color verde	81-82
El número 6.....	83-84
Primero – último	85-86
Números ordinales	87-88
El rectángulo	89-90
Numero 7	91-92
Repaso de numero	93-94
Relación numeral – cantidad	95-96
El numero 8	97-98
Secuencia de color	99-100
Igual – diferente	101- 102
Color anaranjado	103-104
Figuras simples	105
Absurdos.....	106-107
El número 9	108-109
El óvalo	110-111
El número 10.....	112-113
Práctica de números del 1 al 10	114
Grande -pequeño-mediano.....	115-116
Entero mitad	117
Entero -partido.....	118
Objetos ocultos	119-120
El color blanco.....	121-122
Direccionalidad	123
Mas – menos.....	124-127
Color morado	128-129
Conjunto	130
Correspondencia	131
Secuencia por tamaño	132-133
Color negro	134-135
Figuras iguales	136
Figuras incompletas	137

COLOR ROJO

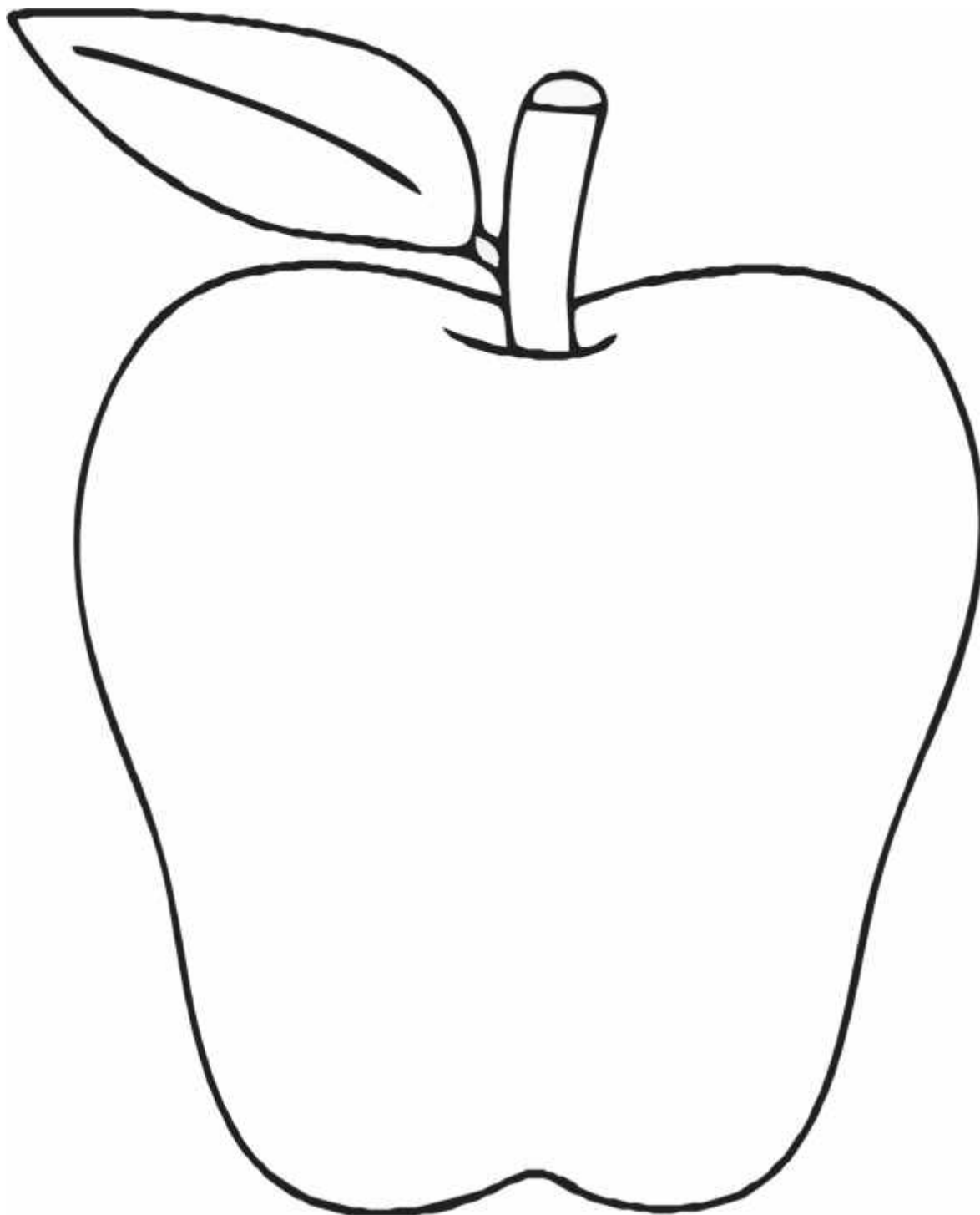

PEGA PAPEL RASGADO DE COLOR ROJO EN LA MANZANA



Pinta de color rojo (●) y embolilla por los puntos con papel rojo (●) por el borde del tomate.

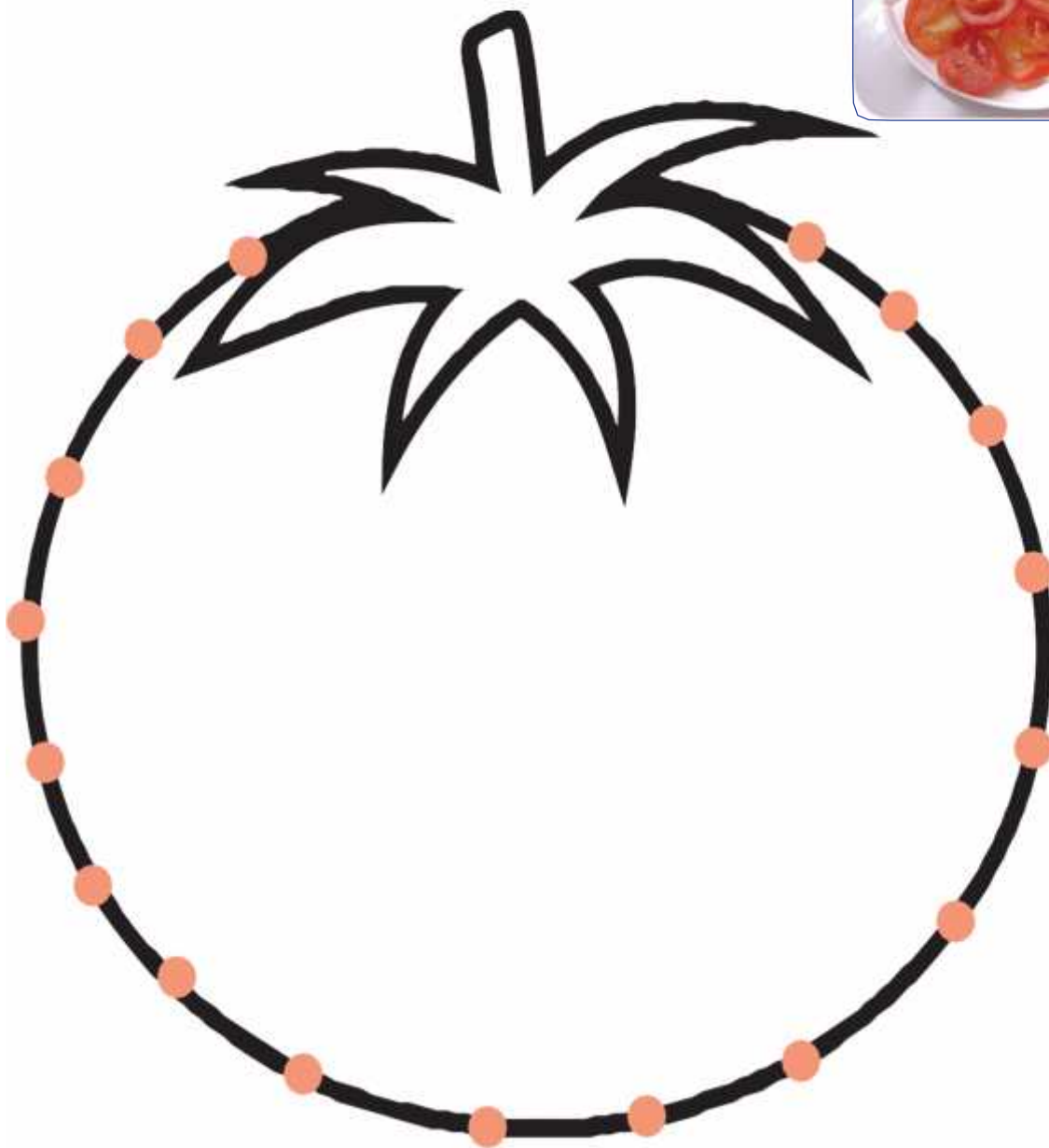

CÍRCULO



DELINEA EL CONTORNO DEL CÍRCULO



PINTA EL CÍRCULO CON CRAYOLA DE COLOR ROJO

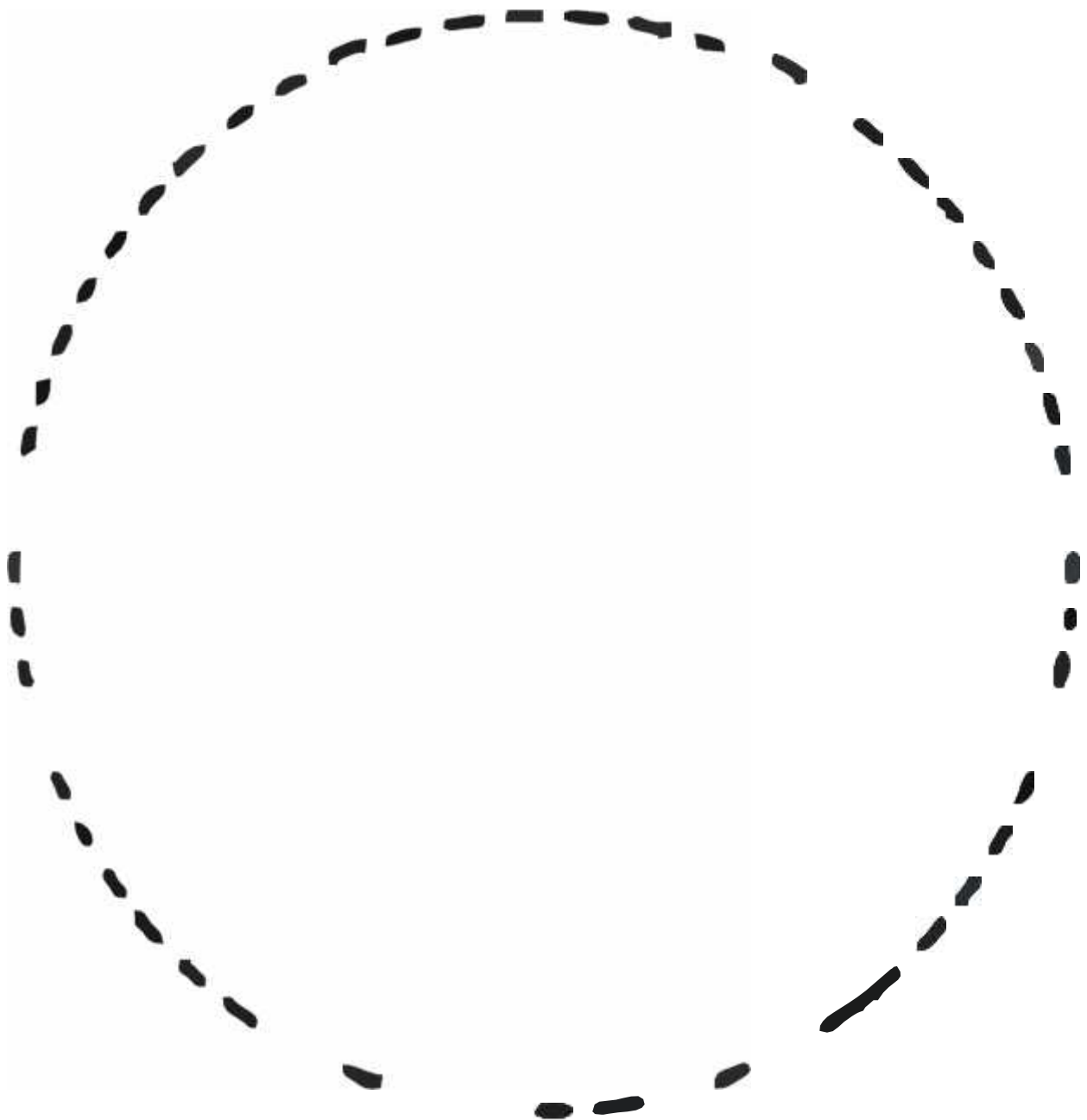



PEGA BOLITAS DE PLASTILINA ALREDEDOR DEL CÍRCULO

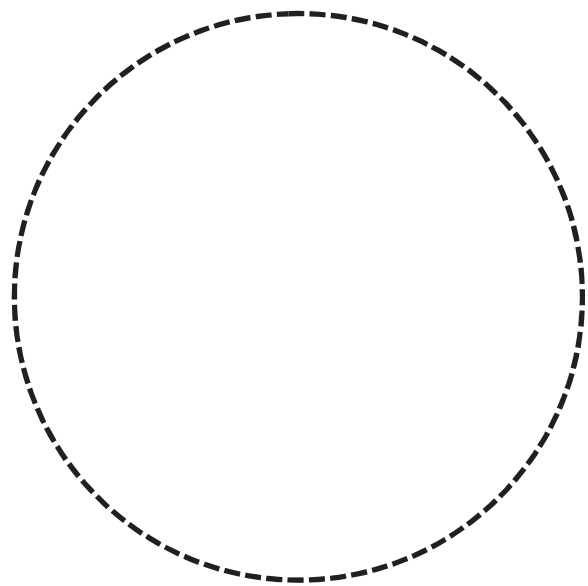
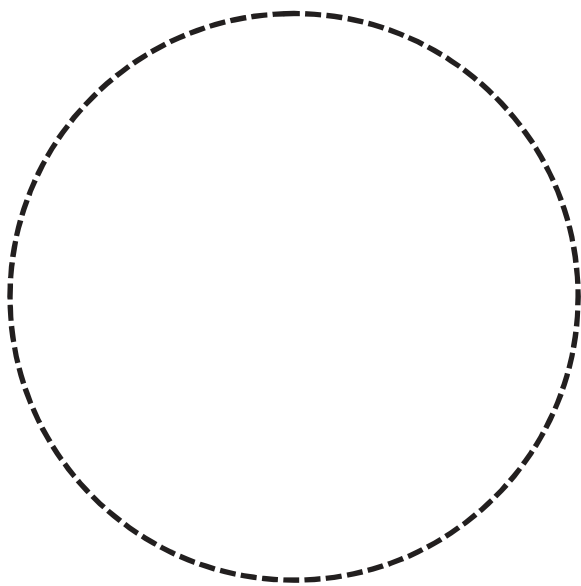
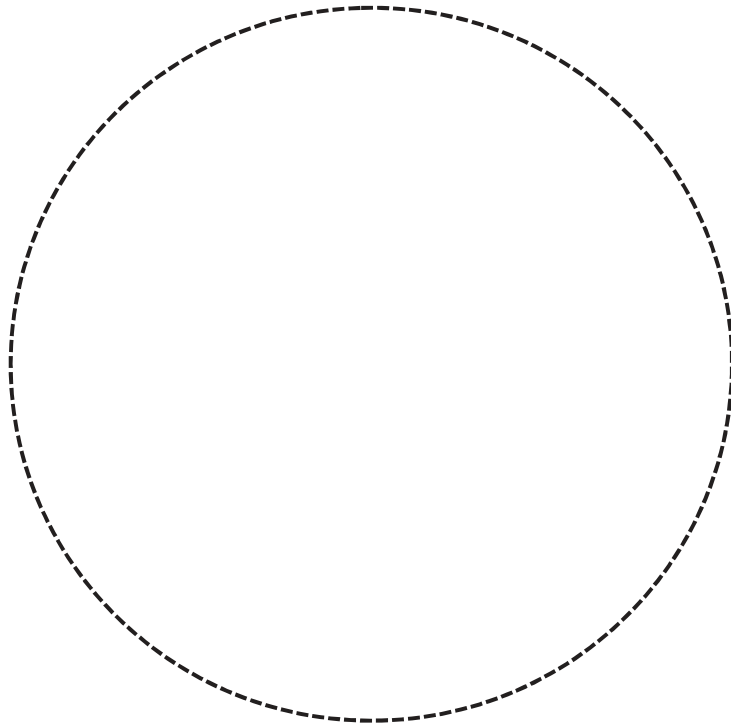



PINTA CON TEMPERA DE COLOR ROJO UTILIZANDO LAS YEMAS DE TU DEDO LOS CÍRCULOS DENTRO DEL ELEFANTE

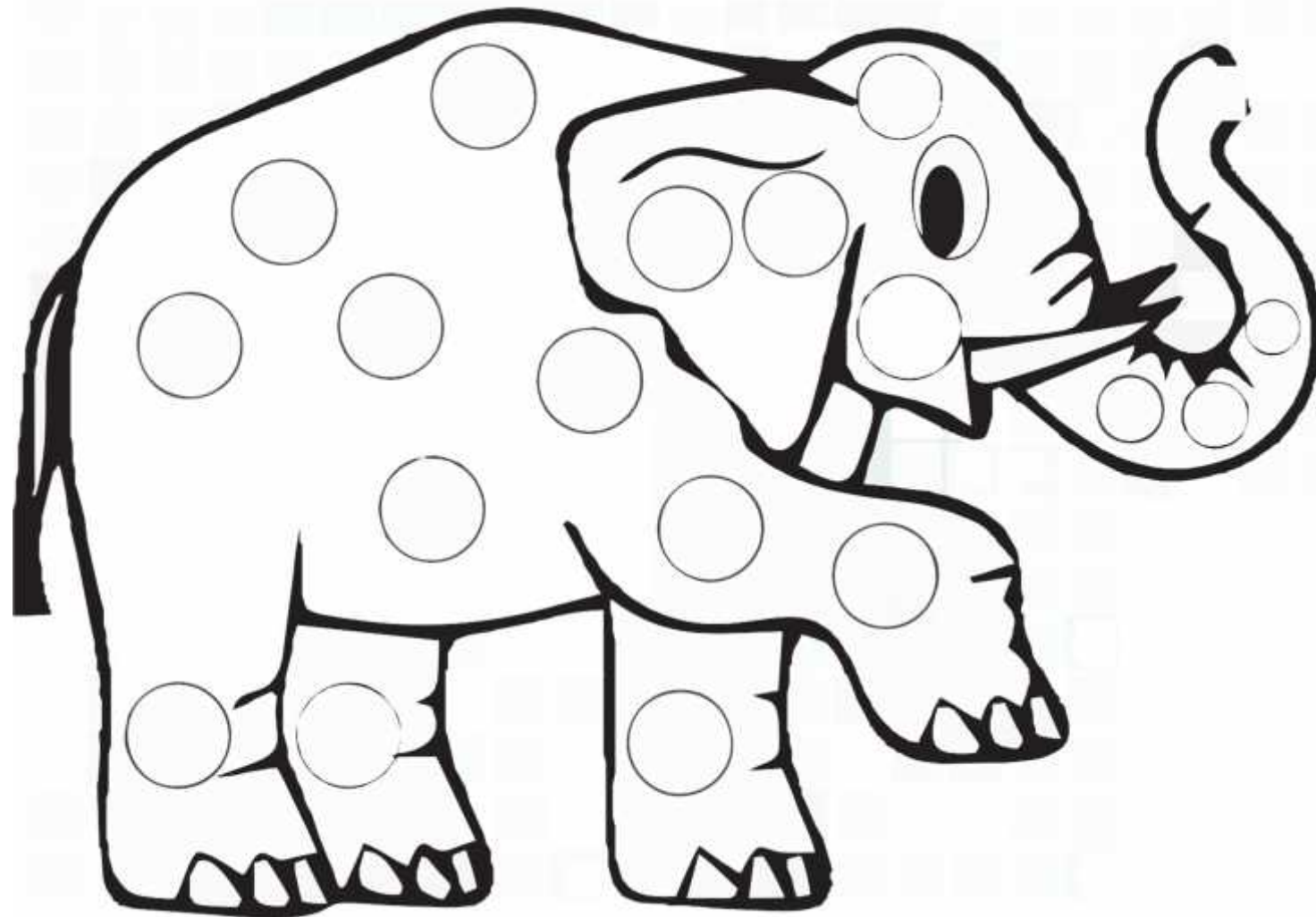



ARRIBA -ABAJO

MARCA CON UNA X LAS MANZANAS QUE ESTÁN ARRIBA DEL ÁRBOL Y



ENCIERRA EN UN CÍRCULO LAS MANZANAS QUE ESTÁN ABAJO

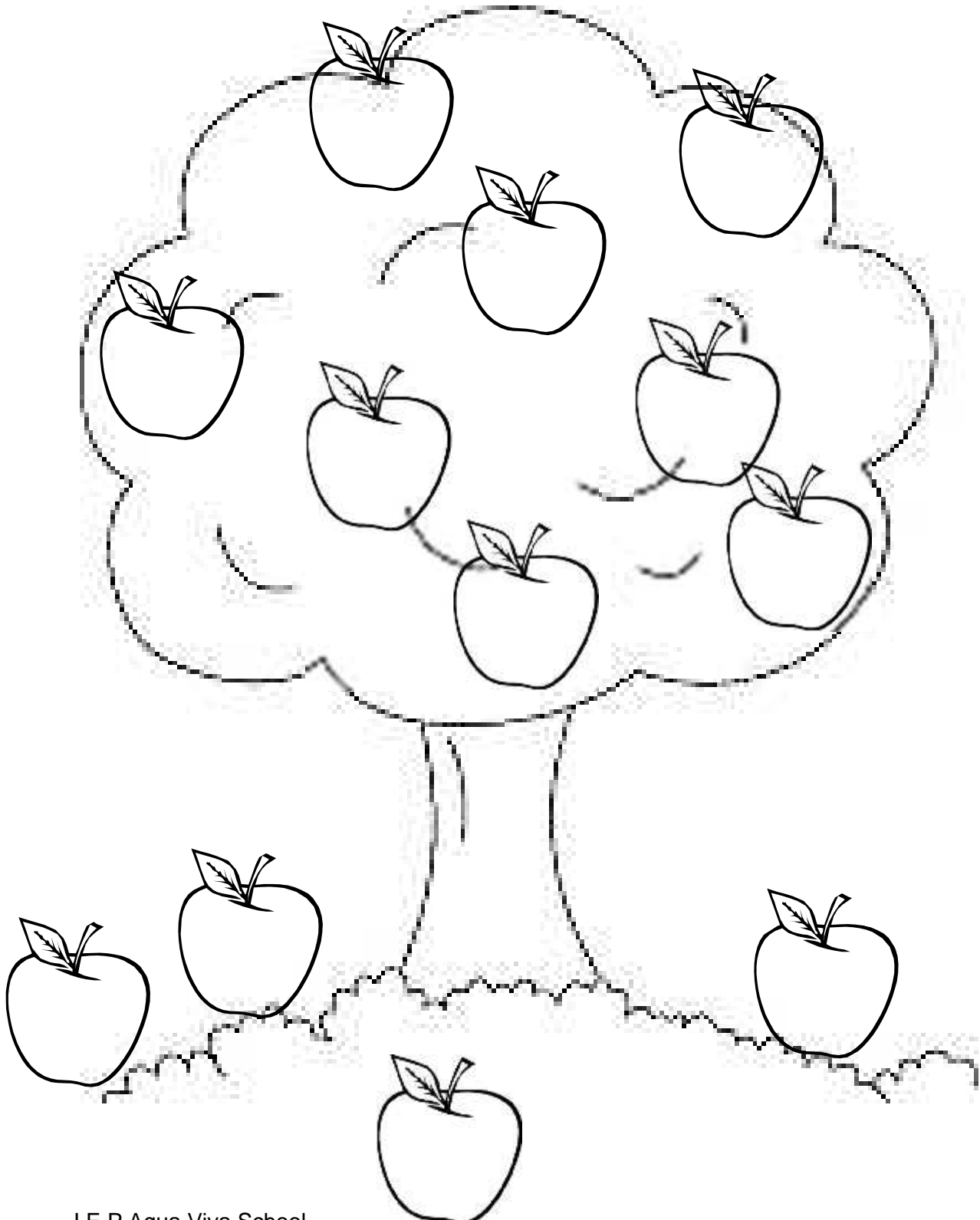

IMITA LAS ACCIONES DEL NIÑO CON GUÍA DE PROFESORA



Dentro – Fuera



Pega plastilina al rededor de la niña que está afuera de la casa.

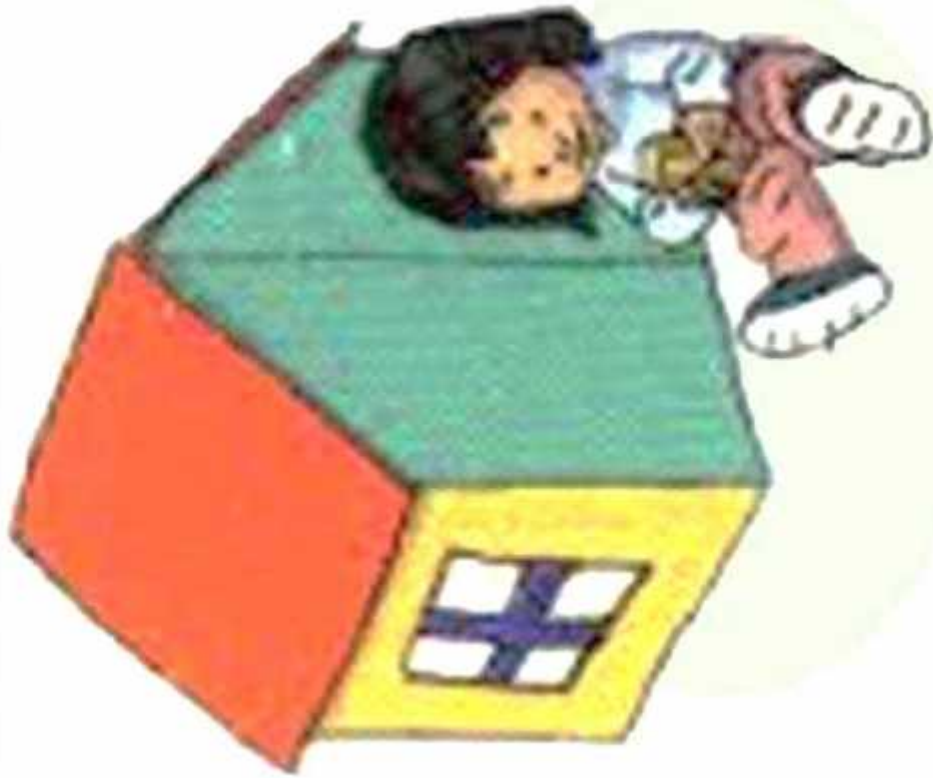
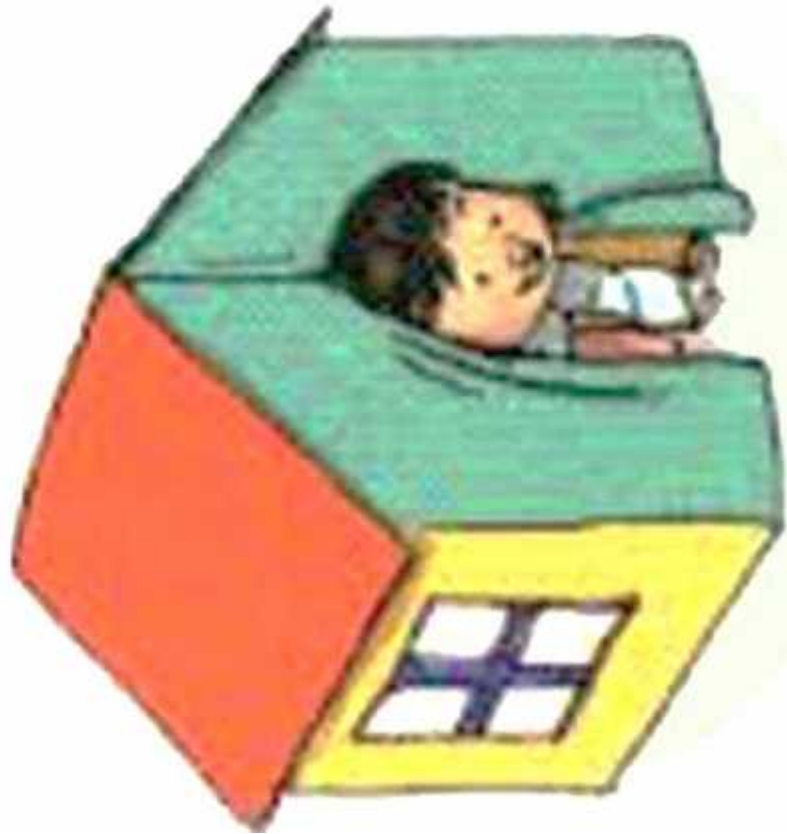



COLOREA AL GATO QUE ESTÁ DENTRO DE LA CANASTA

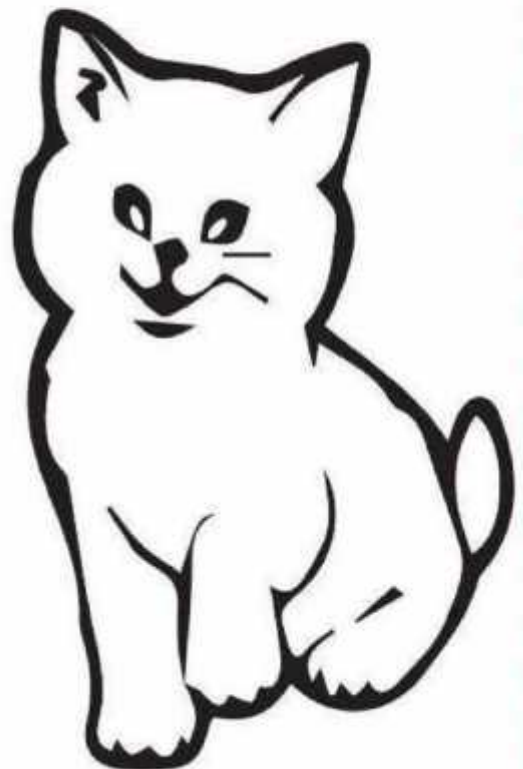



DEJA TUS HUELLITAS CON TEMPERA DE COLOR AZUL



I.E.P Agua Viva School



COLOREA EL SHORT DE COLOR AZUL



GRANDE -PEQUEÑO



COLOREA AL ANIMAL MÁS GRANDE Y ENCIERRA AL ANIMAL PEQUEÑO

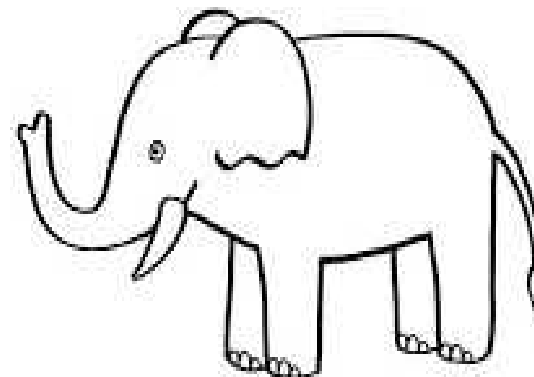
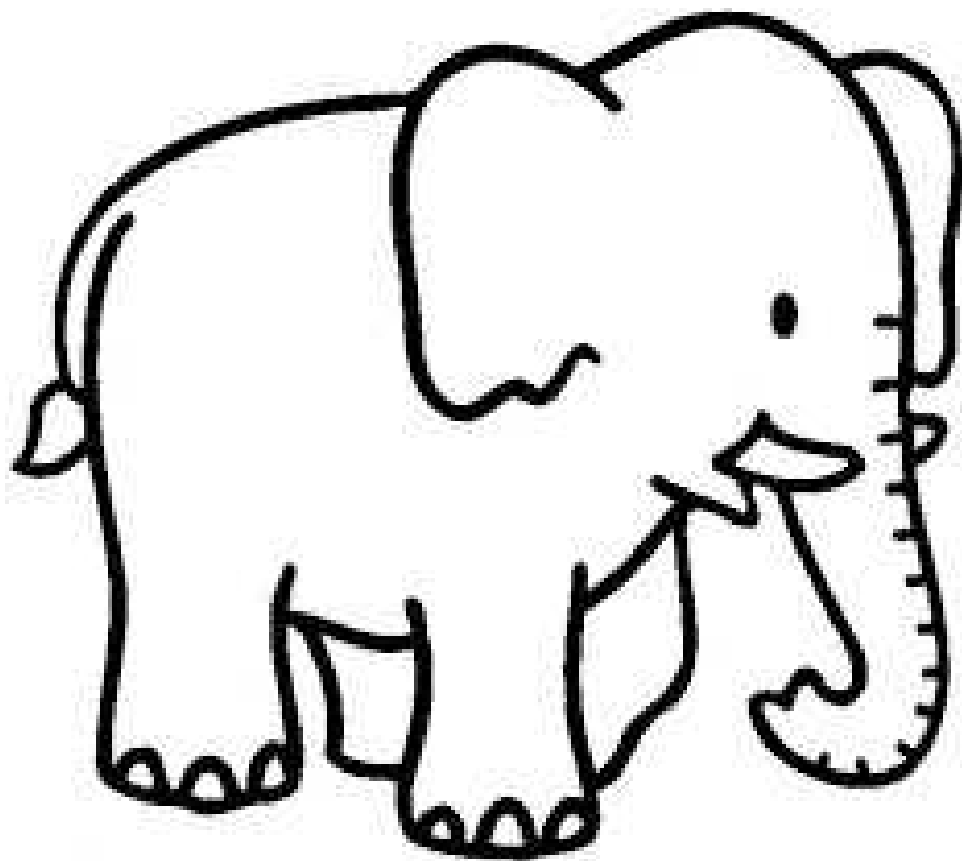



PEGA PLASTILINA EN EL CARACOL GRANDE.

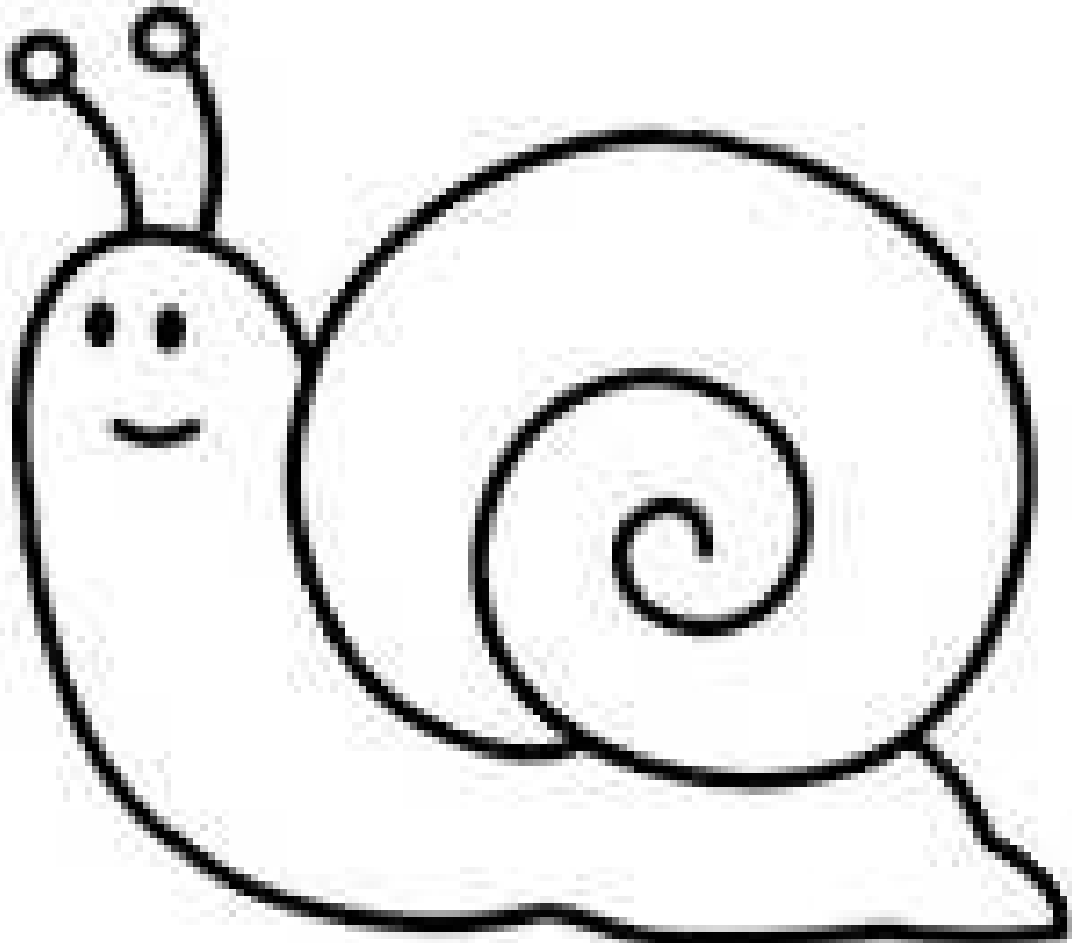



Encima – Debajo

Encierra a la niña que está encima de la mesa.



ENCIMA- DEBAJO

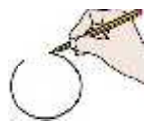

RODEA AL RATÓN QUE ESTA ENCIMA DE LA MESA

ALTO- BAJO

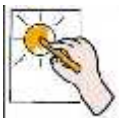
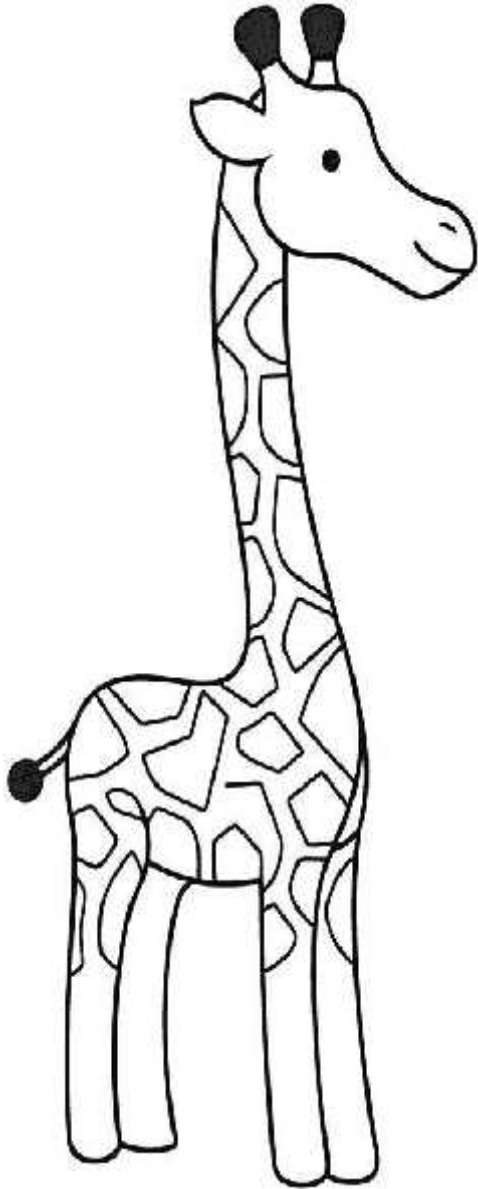

COLOREA DE AMARILLO EL ANIMAL MAS GRANDE



Rasga papel en el árbol bajo y encierra (O) el árbol alto.

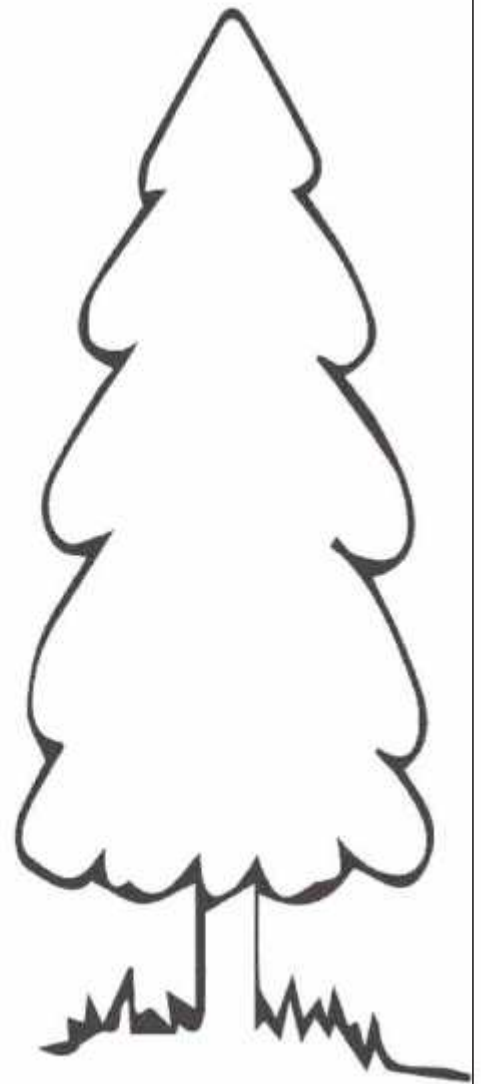
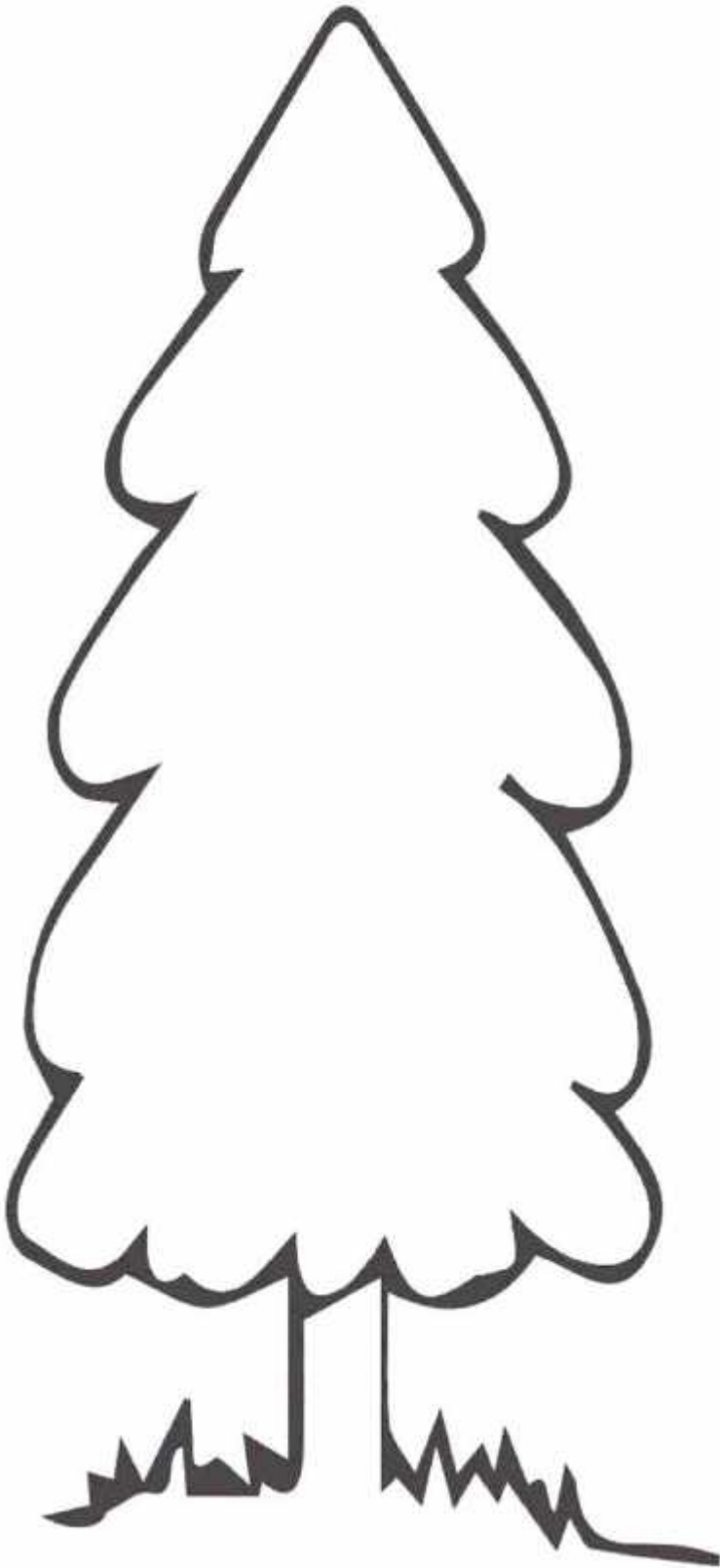

Abierta - Cerrada



Colorea la caja cerrada.

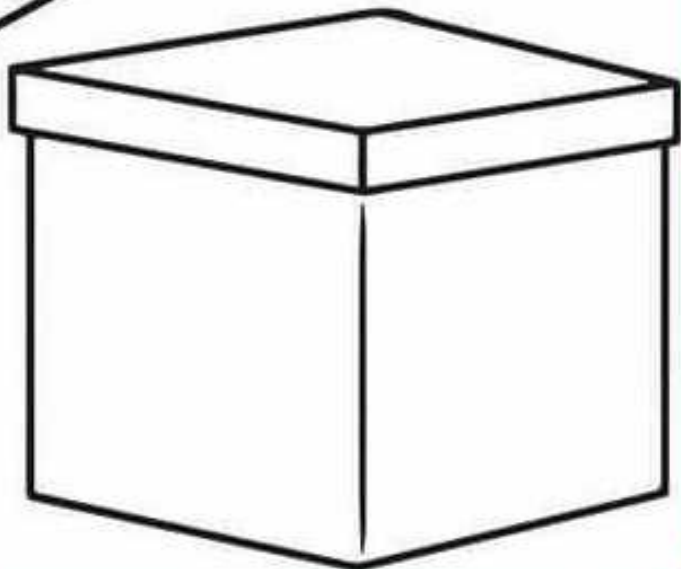
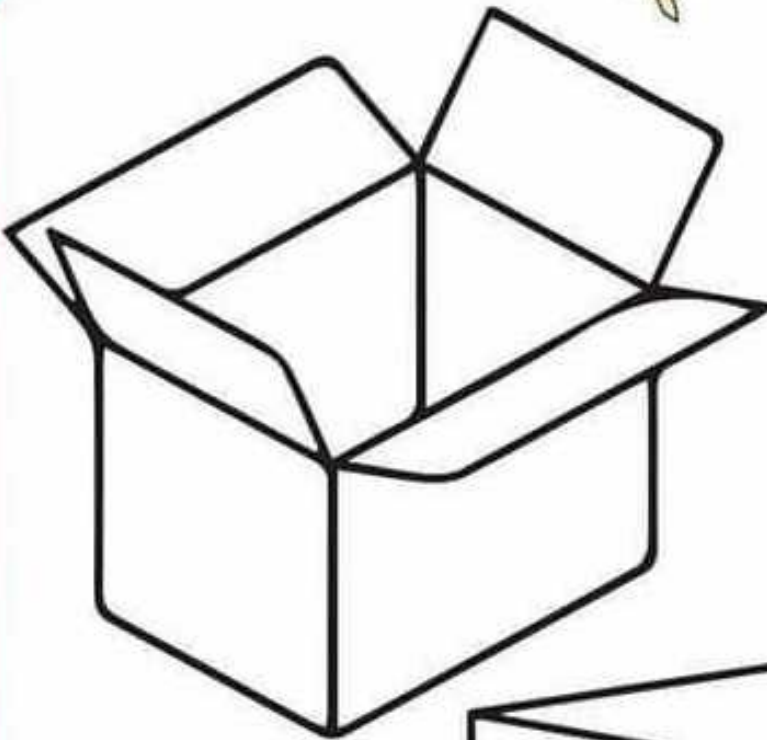



Pega serpentina al borde de la puerta abierta y marca (X) la puerta cerrada.

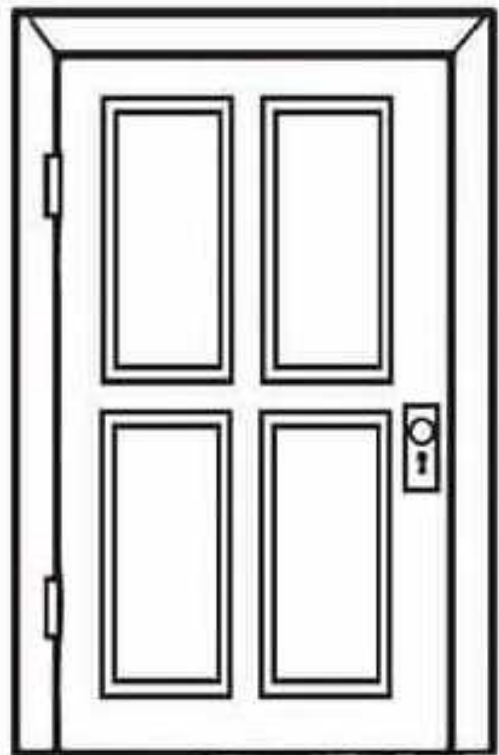
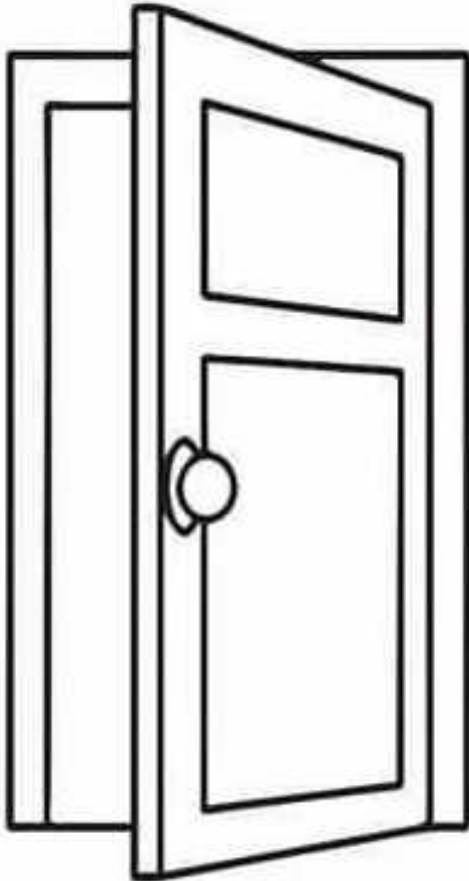

El cuadrado



◆ Embolilla papel azul al borde del cuadrado.

Soy el cuadrado.
Repasa mis cuatro
lados y coloréame.

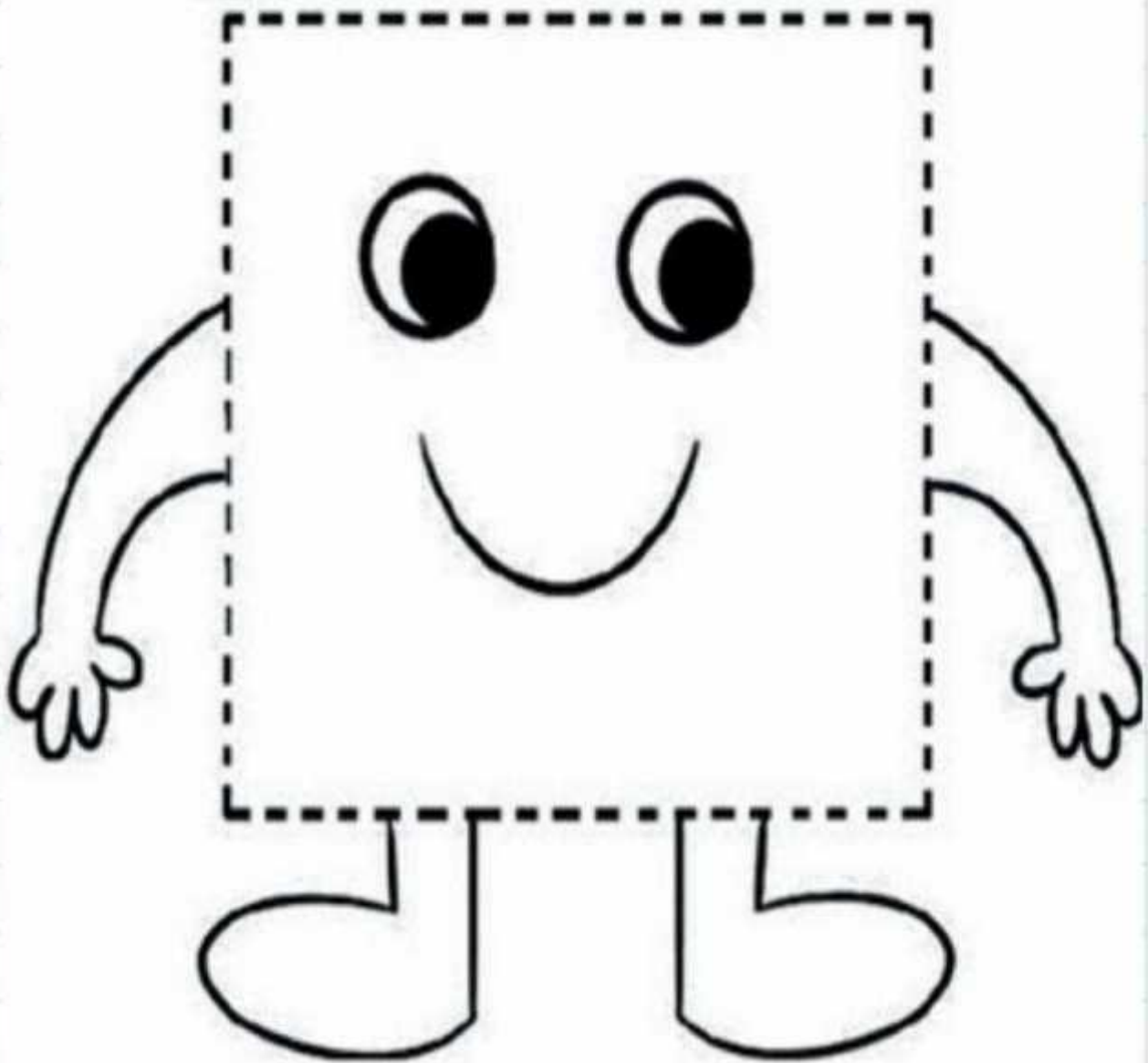

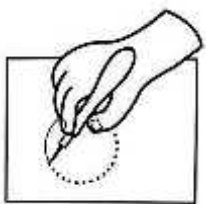

Traza el cuadrado con plumón.

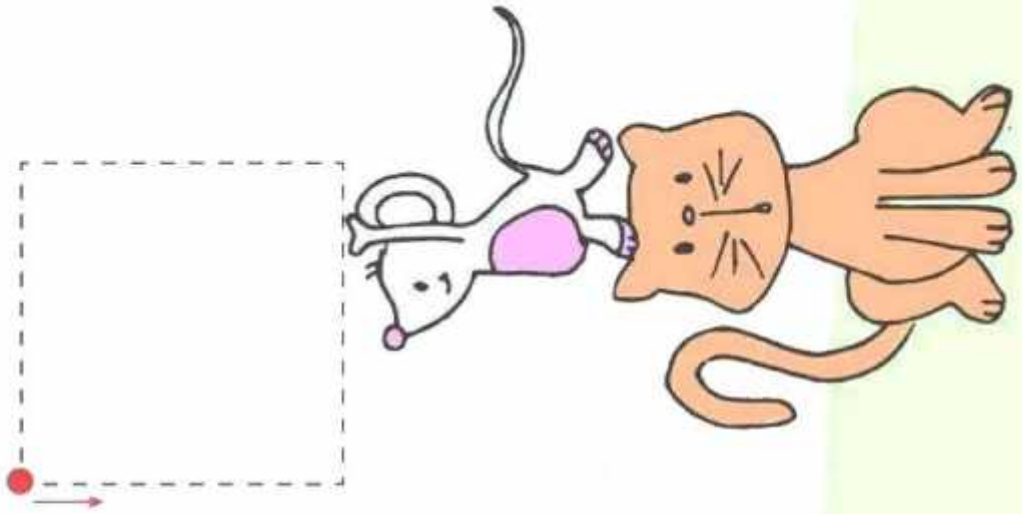
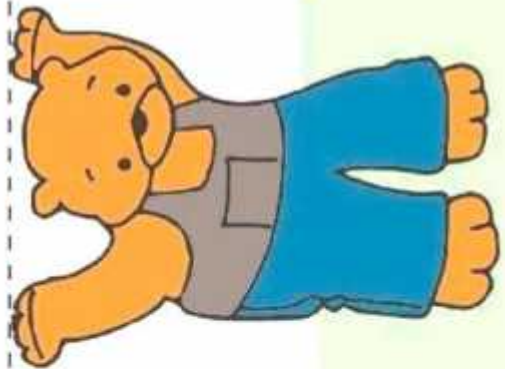
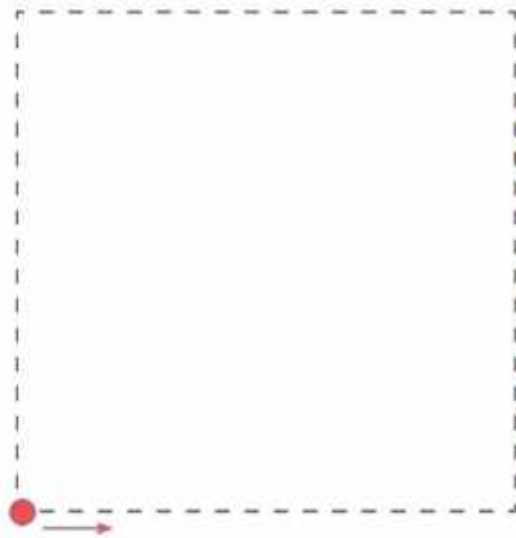

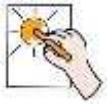

Colorea el plátano de color amarillo con tempera.

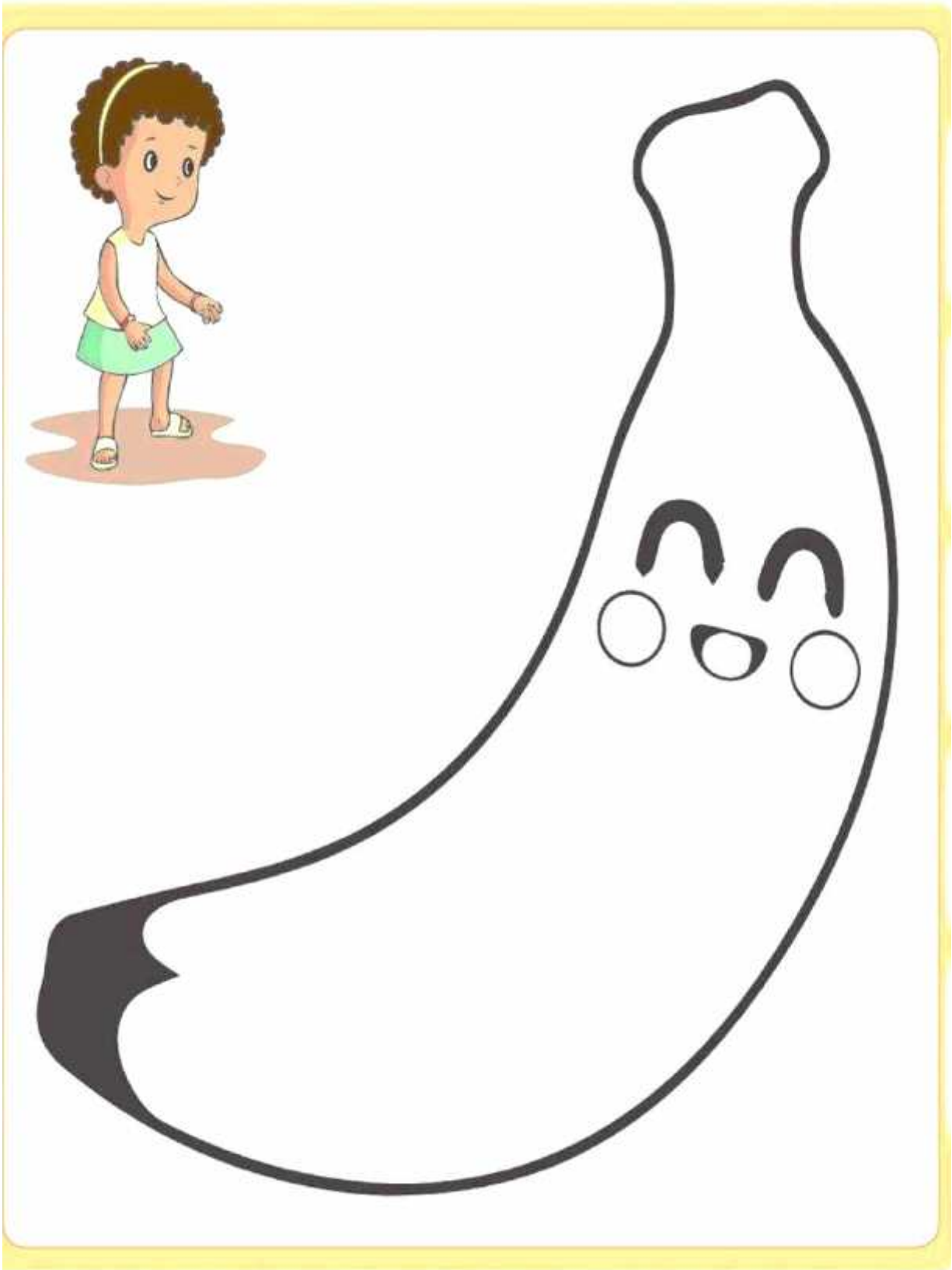

COLOR AMARILLO

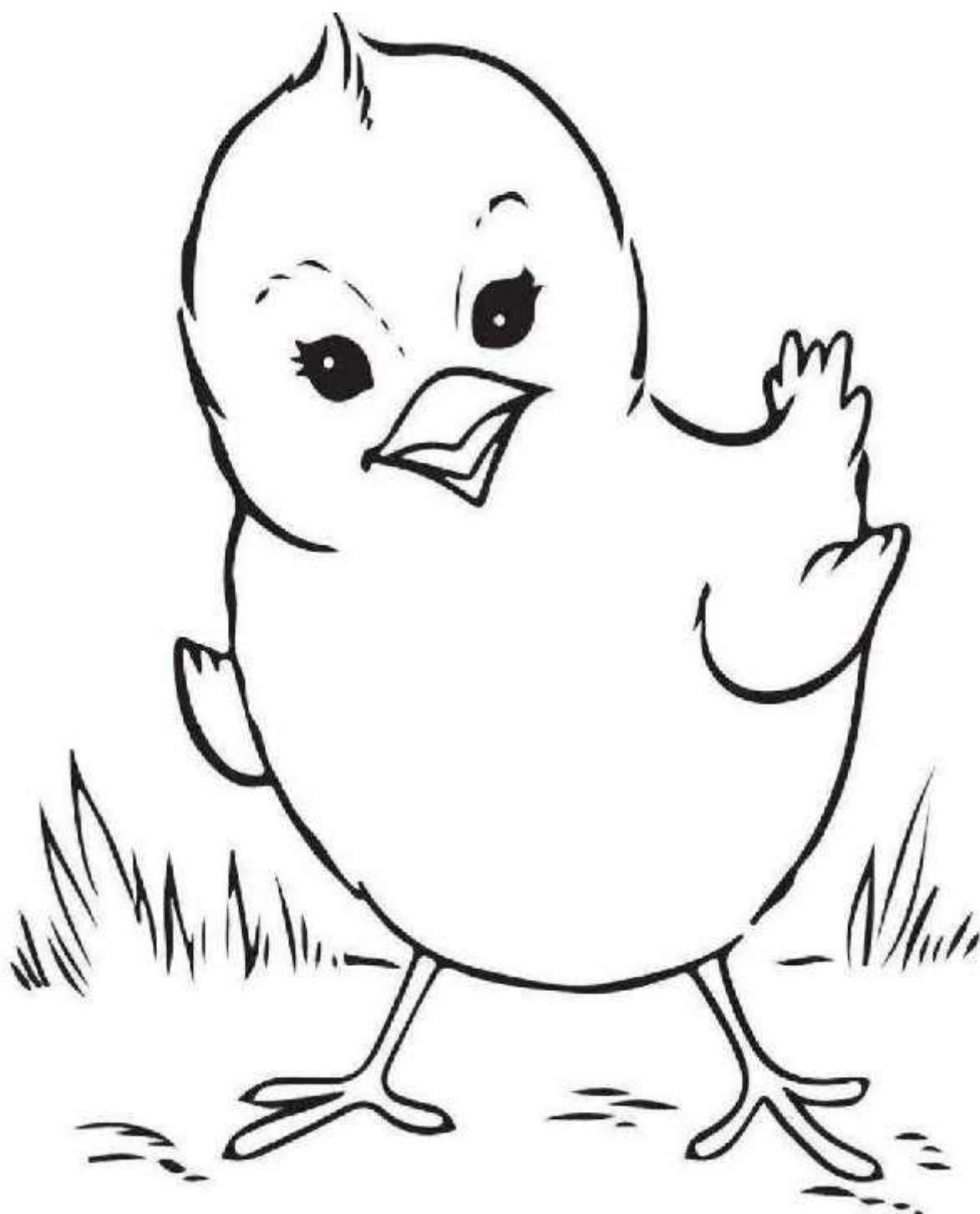

COLOCA TUS HUELLITAS CON TÉMPERA AMARILLA DENTRO DEL POLLITO

JUNTOS -SEPARADOS



Encierra y colorea a los niños que se encuentran juntos: luego marca (X), a los que se hallan separados del grupo.





Colorea los pinceles separados y marca (X) los pinceles juntos.

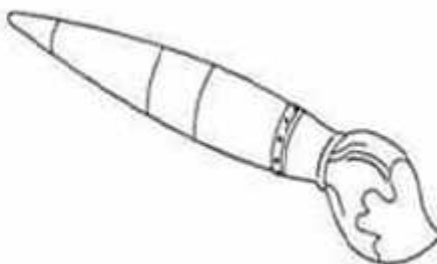
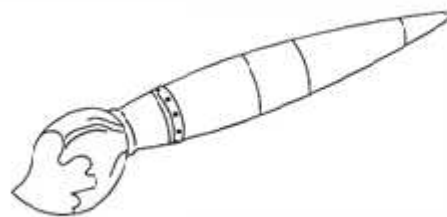
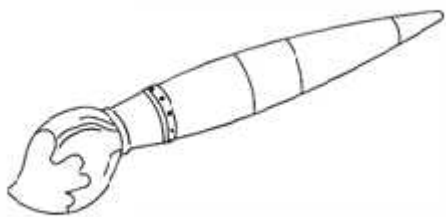
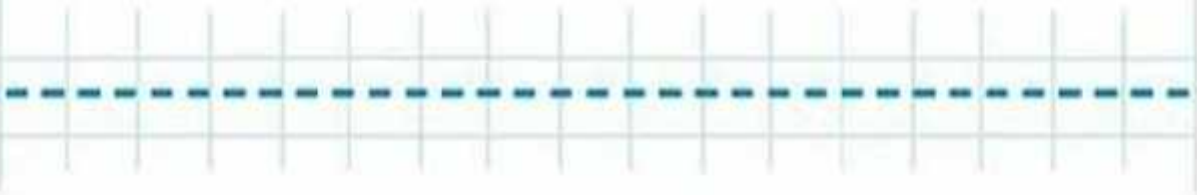
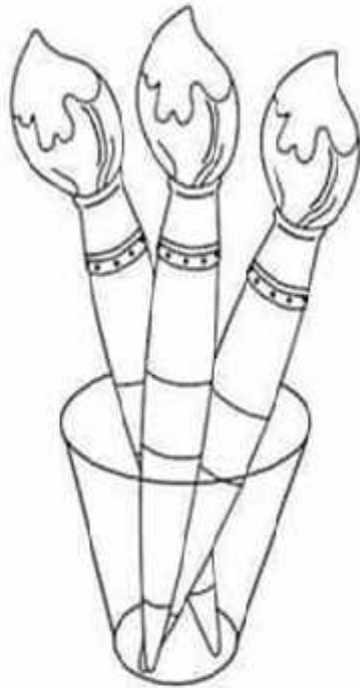

DELANTE - DETRÁS



Punza el borde del niño que está detrás de la silla.





Marca (X) al niño que está delante de su padre.

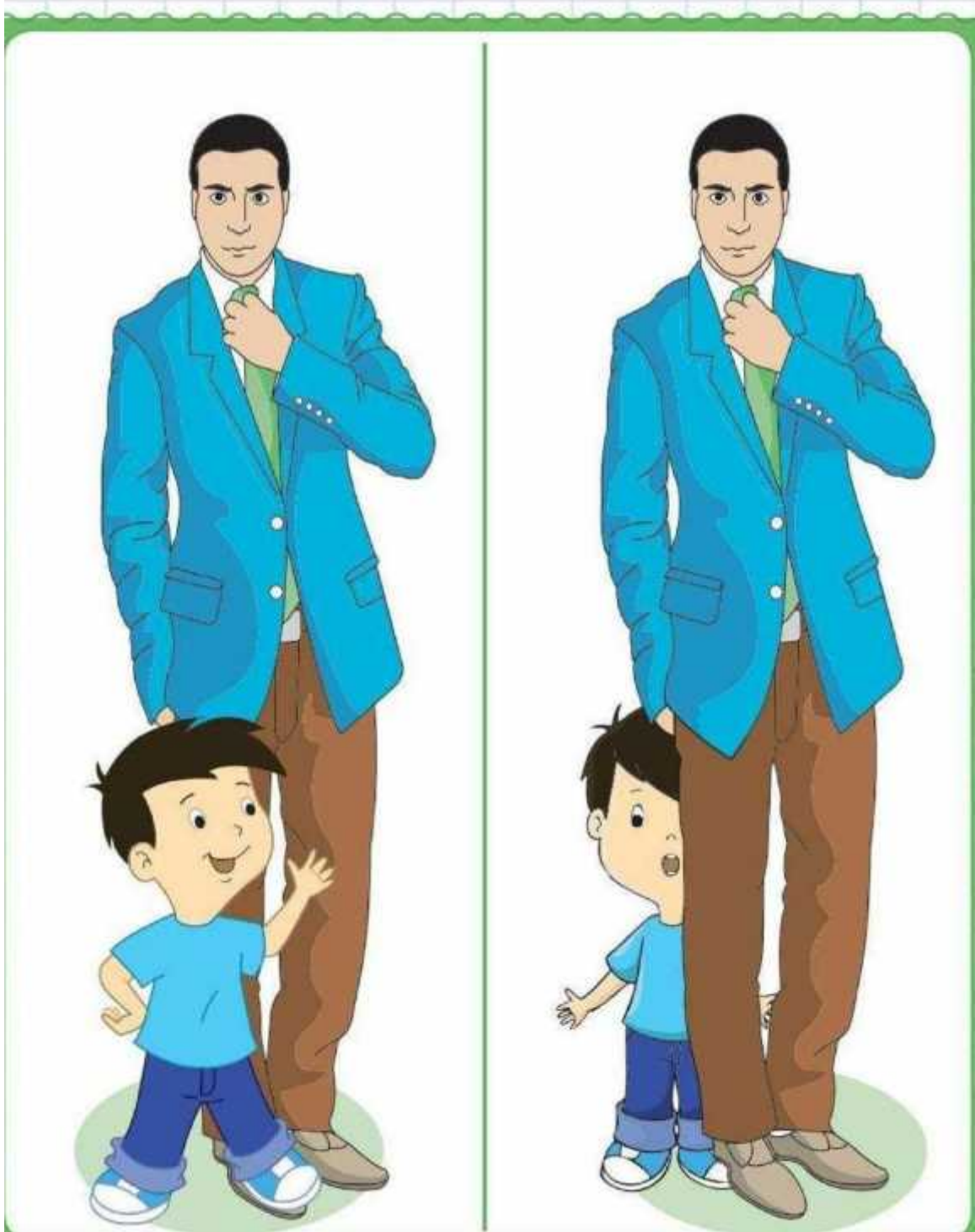



Muchos - Pocos



Marca (X) donde hay muchos niños.





Colorea donde hay muchas paletas.

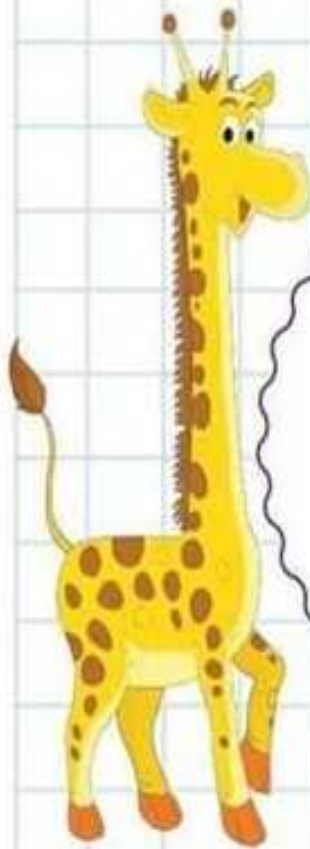
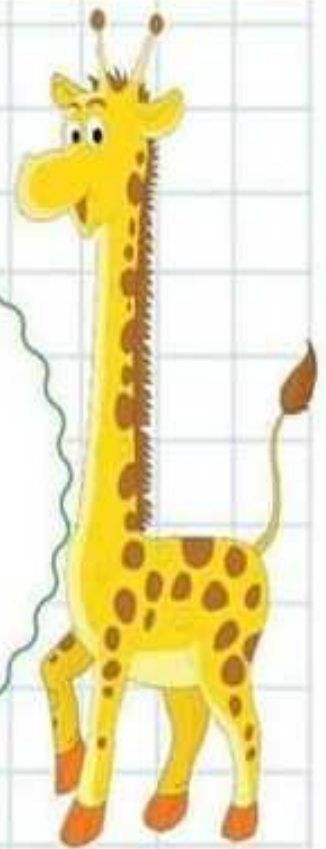

LOS NÚMEROS

¿QUÉ NÚMERO ES?



1



UNO



¿CÓMO SE ESCRIBE? PASA TU LÁPIZ POR EL PLUMÓN AMARILLO



REPASA POR LAS LÍNEAS PUNTEADAS EL NÚMERO

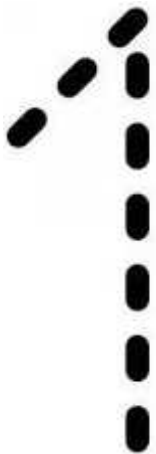

1



EL NÚMERO 1



Colorea el pollito y pega bolitas de papel en el N° 1.

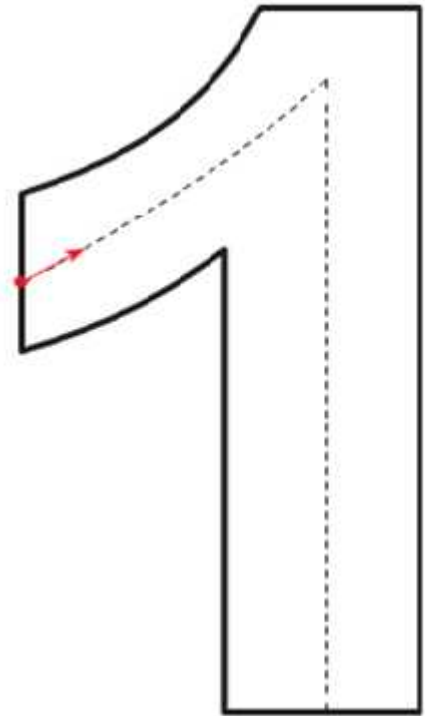
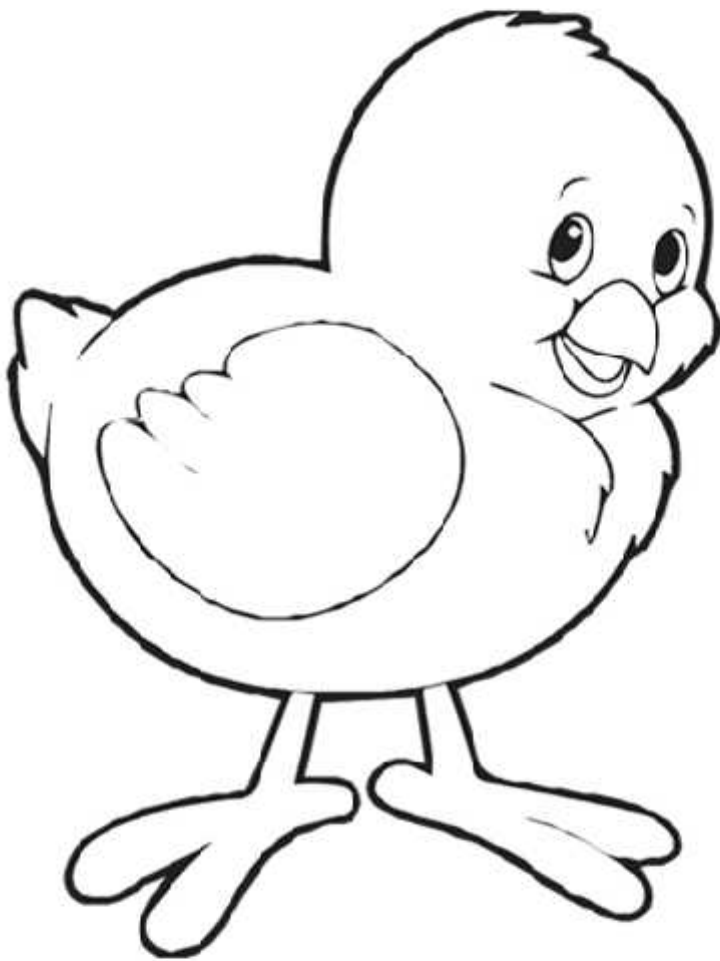

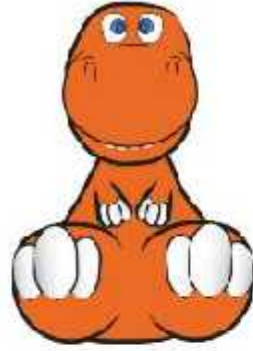
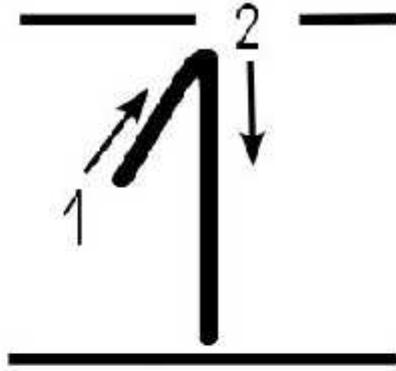

Practica el número 1:

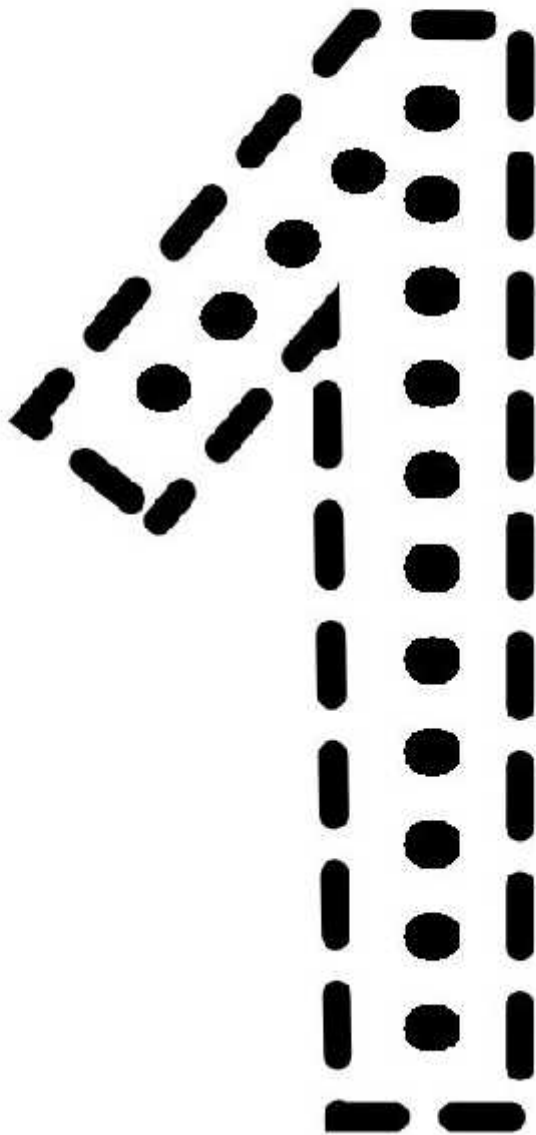

¿QUÉ NÚMERO ES?

1

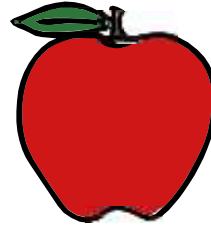
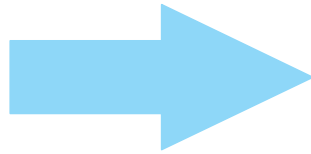

PALABRA

UNO



SÍLABAS

DA PALMADAS, DE ACUERDO A LAS SÍLABAS DE LA PALABRA

U

NO



ESCRITURA TRAZA EL NÚMERO 1

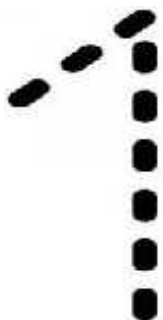

NÚMERO UNO

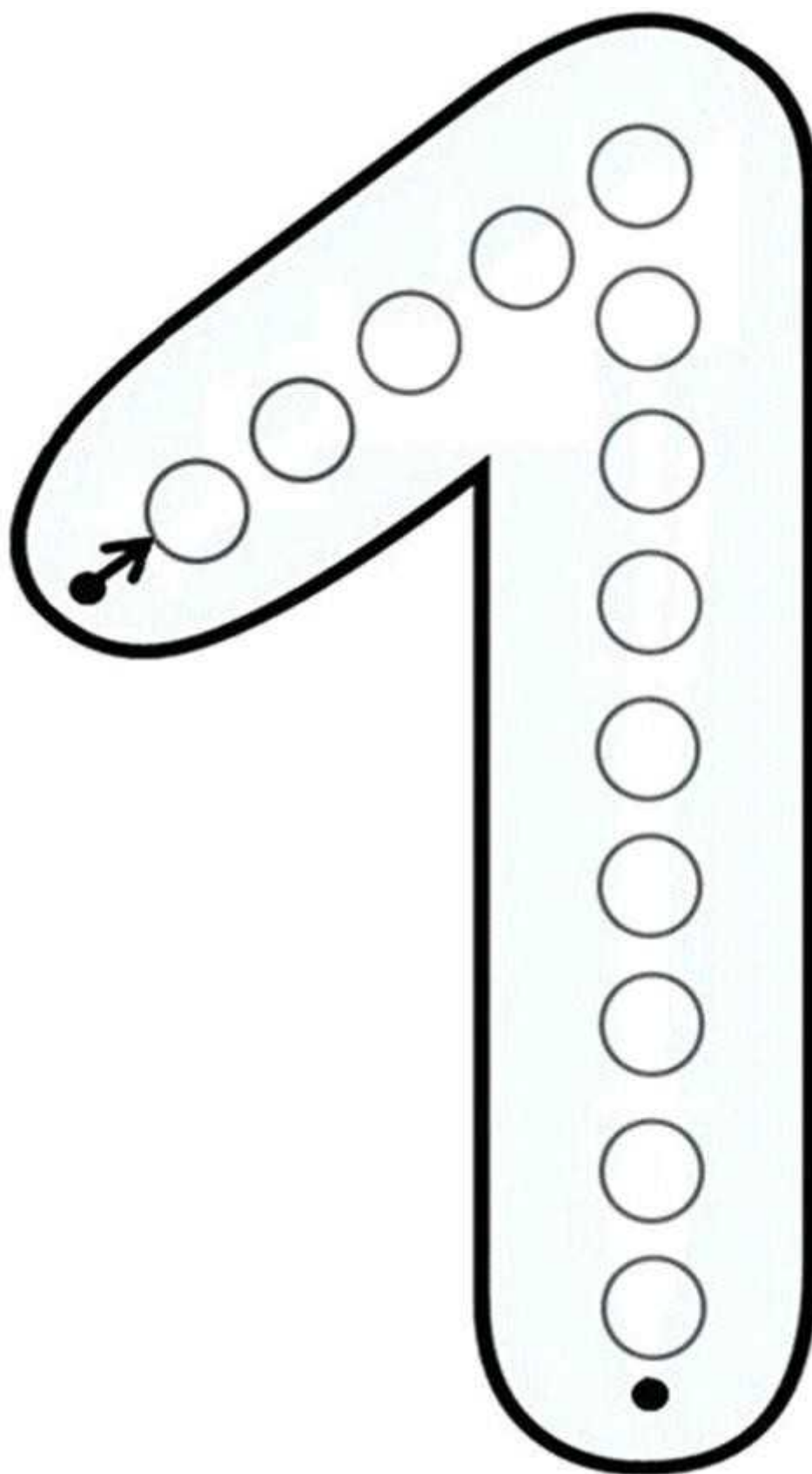

PRESIONA BOLITAS DE PLASTILINA EN LOS CÍRCULOS.



PINTA TODOS LOS NÚMEROS 1 QUE ENCUENTRES EN CIRCULOS.

A grid of numbers in circles for a coloring activity. The number 1 is highlighted in yellow in the top-left corner. A large black number 1 is in the center. Other numbers include 6, 3, 10, 2, 7, 8, 1, 3, 5, 4, 6, 1, 1, 2, 2, 1, 7, 5, 6, 1, 1.

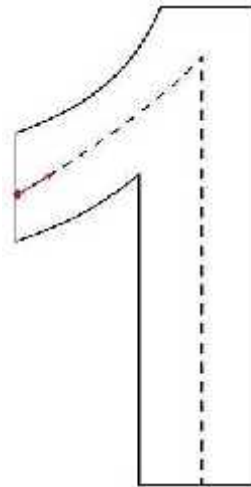

UNO

COLOCA BOLITAS DE PLASTILINA SEGÚN LA CANTIDAD QUE SE TE INDICA.

I.E.P Agua Viva School



Marca con una (X) según el número indicado y colorea el número 1.

--	--	--

--	--	--

--	--	--

--	--	--



UNE CON FLECHAS AL NÚMERO LOS CUADROS QUE TENGAN UN ELEMENTO

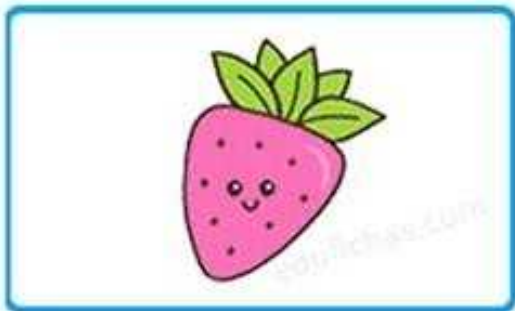
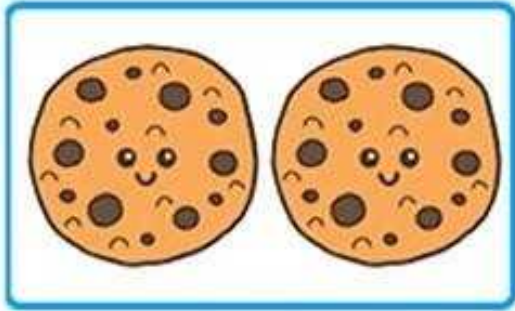

1

UNO

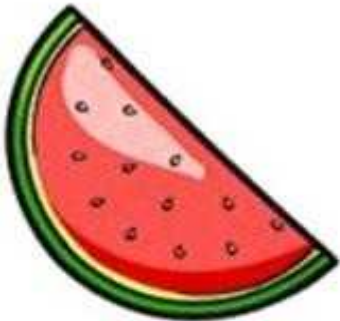

PINTA EL NÚMERO SEGÚN LA CANTIDAD DE ELEMENTOS QUE OBSERVAS

		
5	1	3

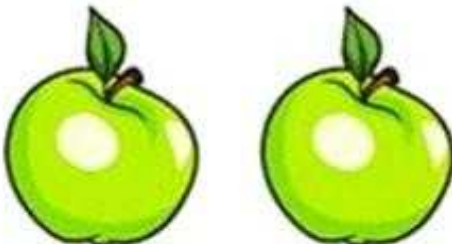
		
1	4	2

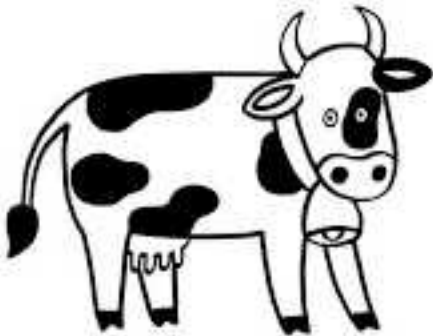
		
3	1	4

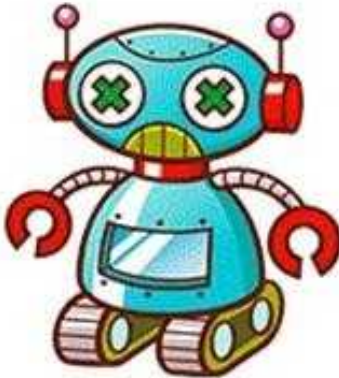
		
5	1	3



Repasa el número 1 con plumón grueso de color.

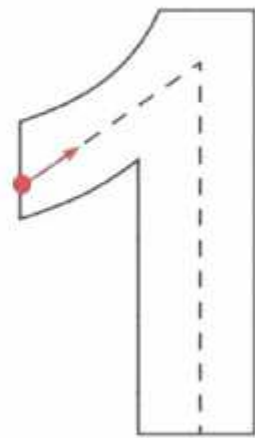
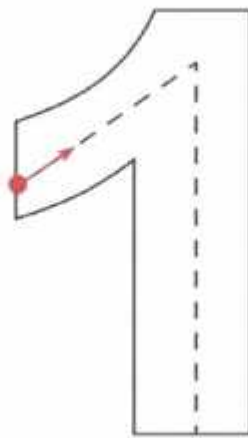
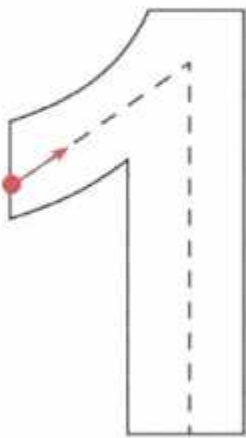
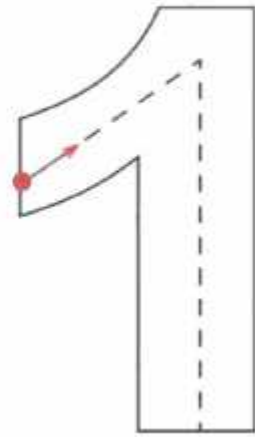
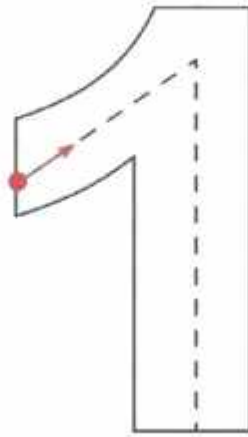
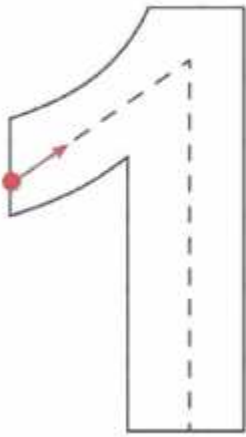
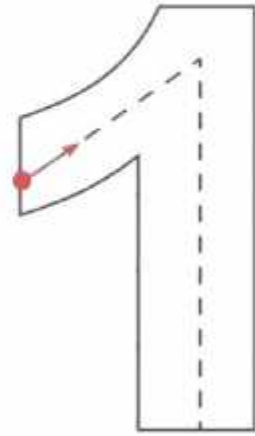
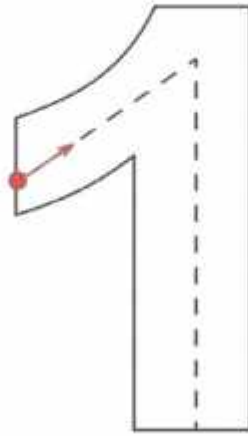
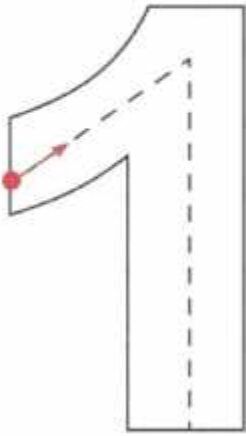

1

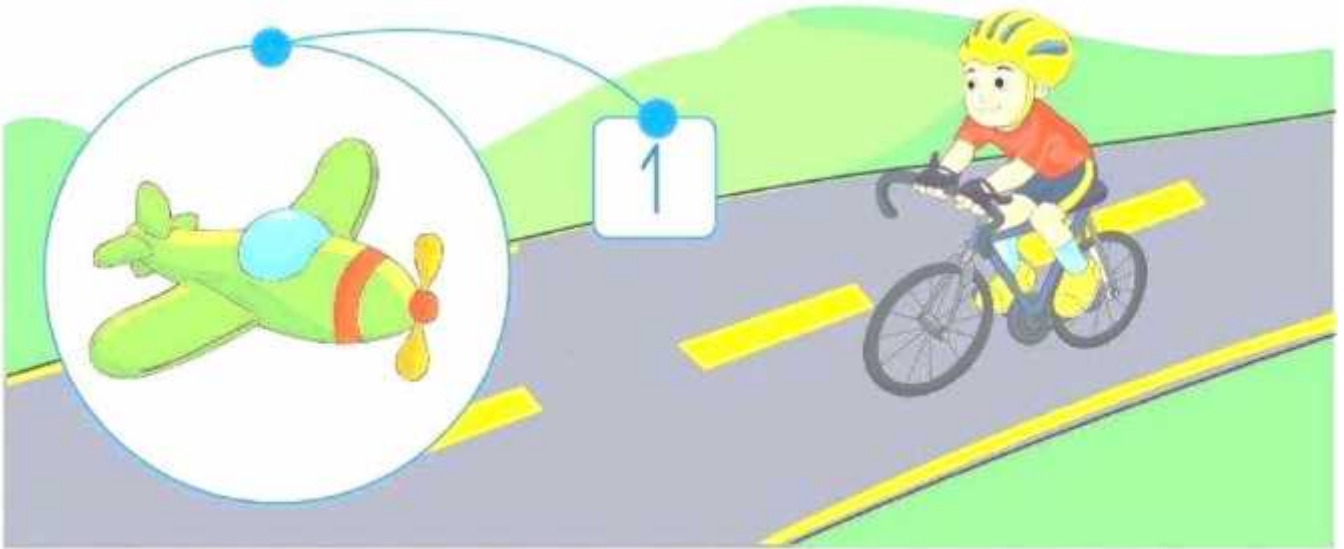

Pinta los conjuntos que tengan un elemento.

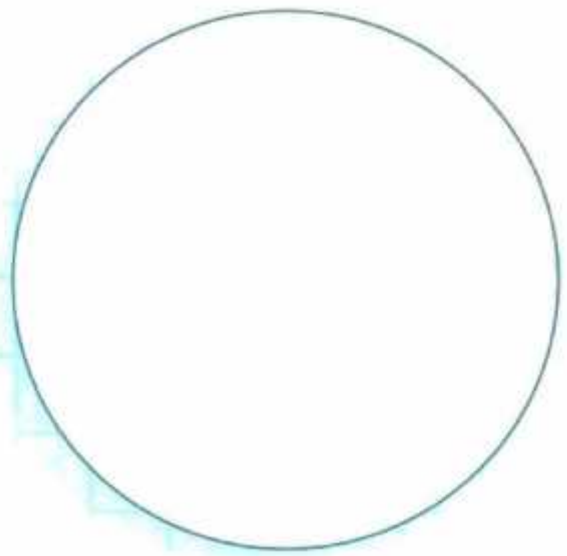
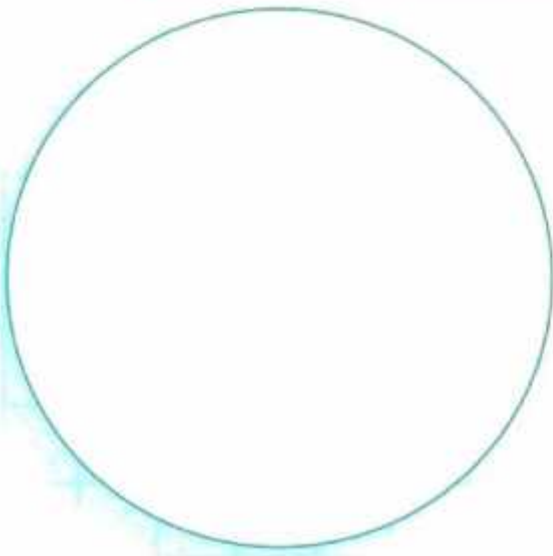

EL NÚMERO 2



Delinea el N° 2 con plumón y colorea los monitos.

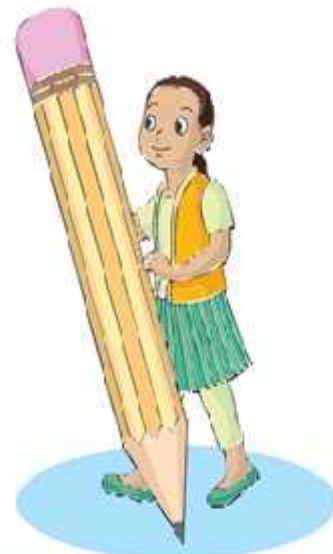
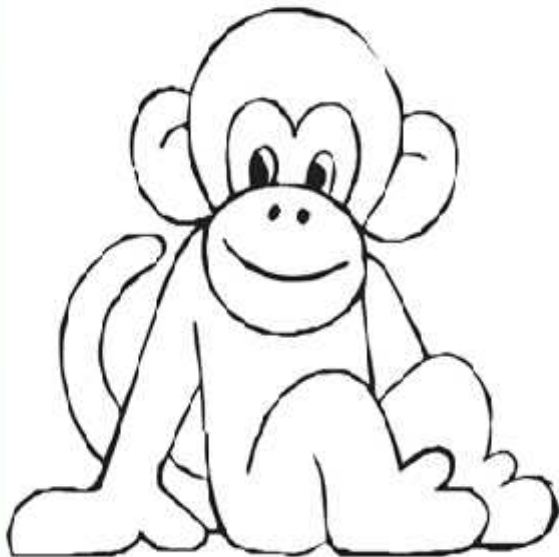
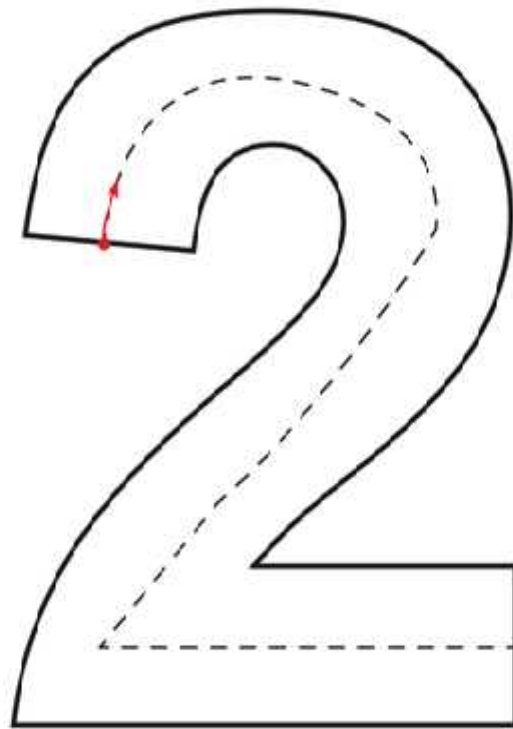
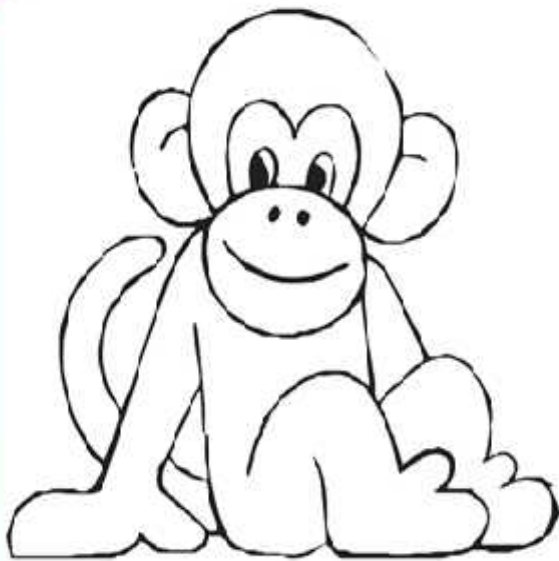

¿QUÉ NÚMERO ES?



DOS



¿CÓMO SE ESCRIBE? PASA TU LÁPIZ POR EL PLUMÓN AMARILLO

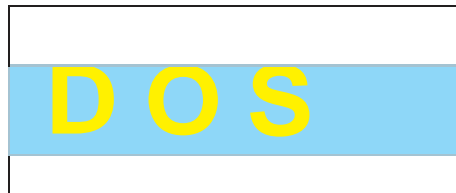

REPASA POR LAS LÍNEAS PUNTEADAS EL NÚMERO 2



¿QUÉ NÚMERO ES?



2

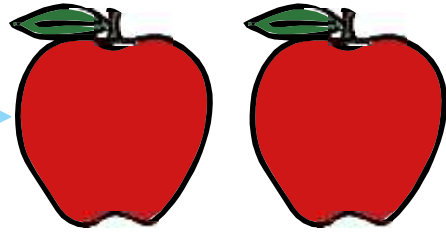
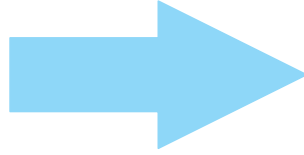

PALABRA

UNO



SÍLABAS

DA PALMADAS, DEACUERDO A LAS SÍLABAS DE LA PALABRA

DOS



ESCRITURA TRAZA EL NÚMERO 2

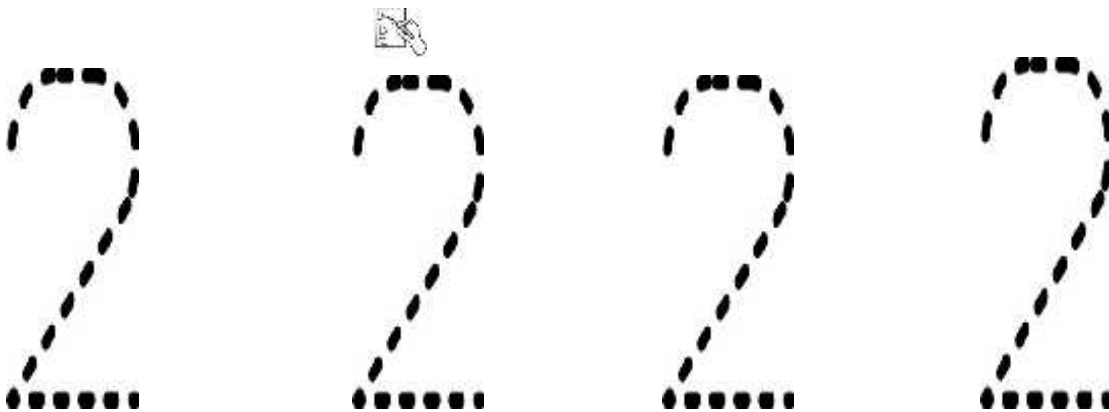



IDENTIFICA EL SIGUIENTE NÚMERO Y COLOREALO

2

3

5

7

2

8

2

5

1

6

9

0

2

4

2

5

7

NÚMERO 2

2

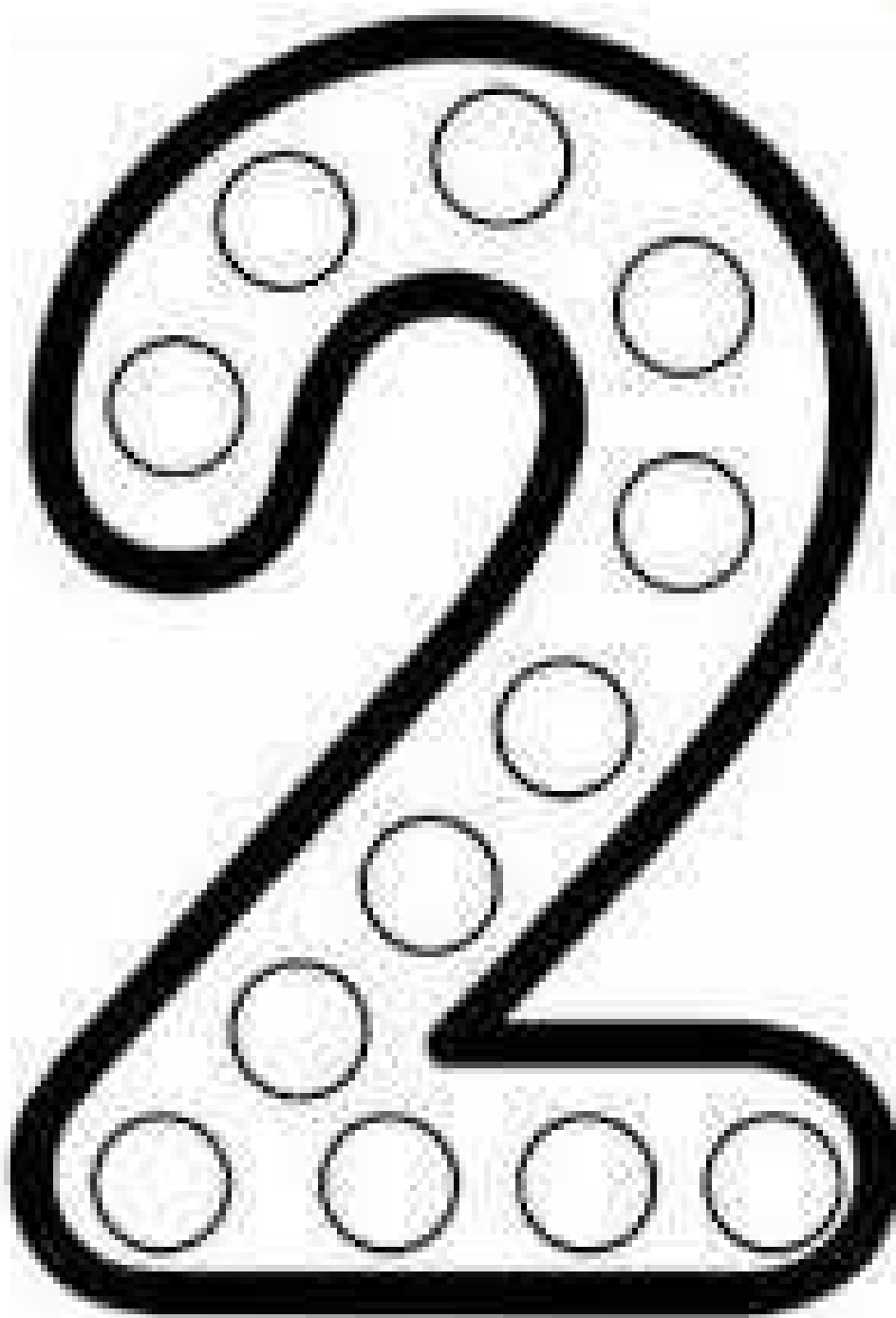

DEJA TUS HUELLITAS EN CADA CÍRCULO

I.E.P Agua Viva School



DOS



COLOCA BOLITAS DE PLASTILINA SEGÚN LA CANTIDAD QUE SE TE INDICA

I.E.P Agua Viva School

2



DOS

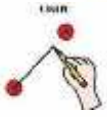

Une los números con la cantidad que corresponde.

2

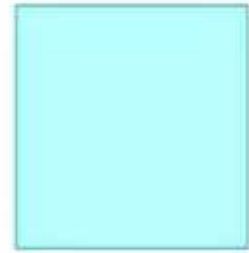

1

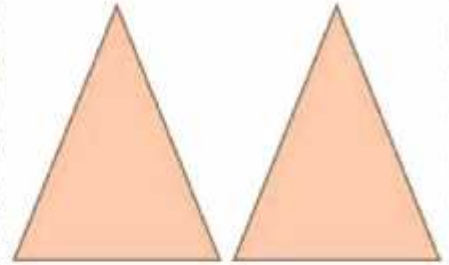

2



1

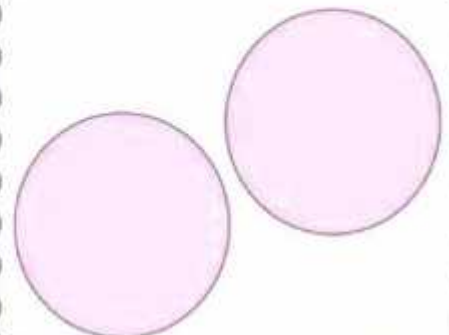



CUENTA LOS ANIMALES Y UNE EL NÚMERO CON LA CANTIDAD QUE CORRESPONDE

2



1

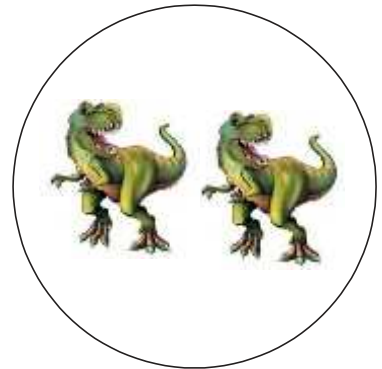

2

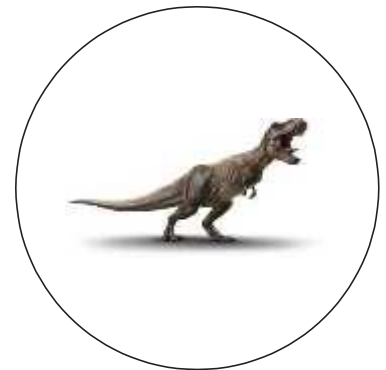

1

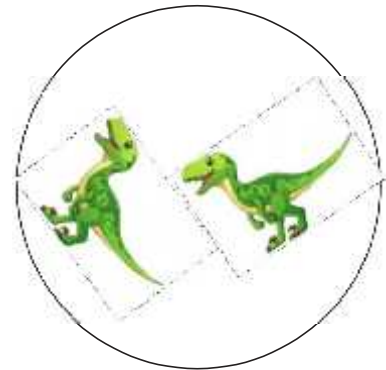

El triángulo

❖ Haz huellitas con tempera, por los puntitos del triángulo.

Soy el triángulo.
Repasa mis tres lados
y coloréame.

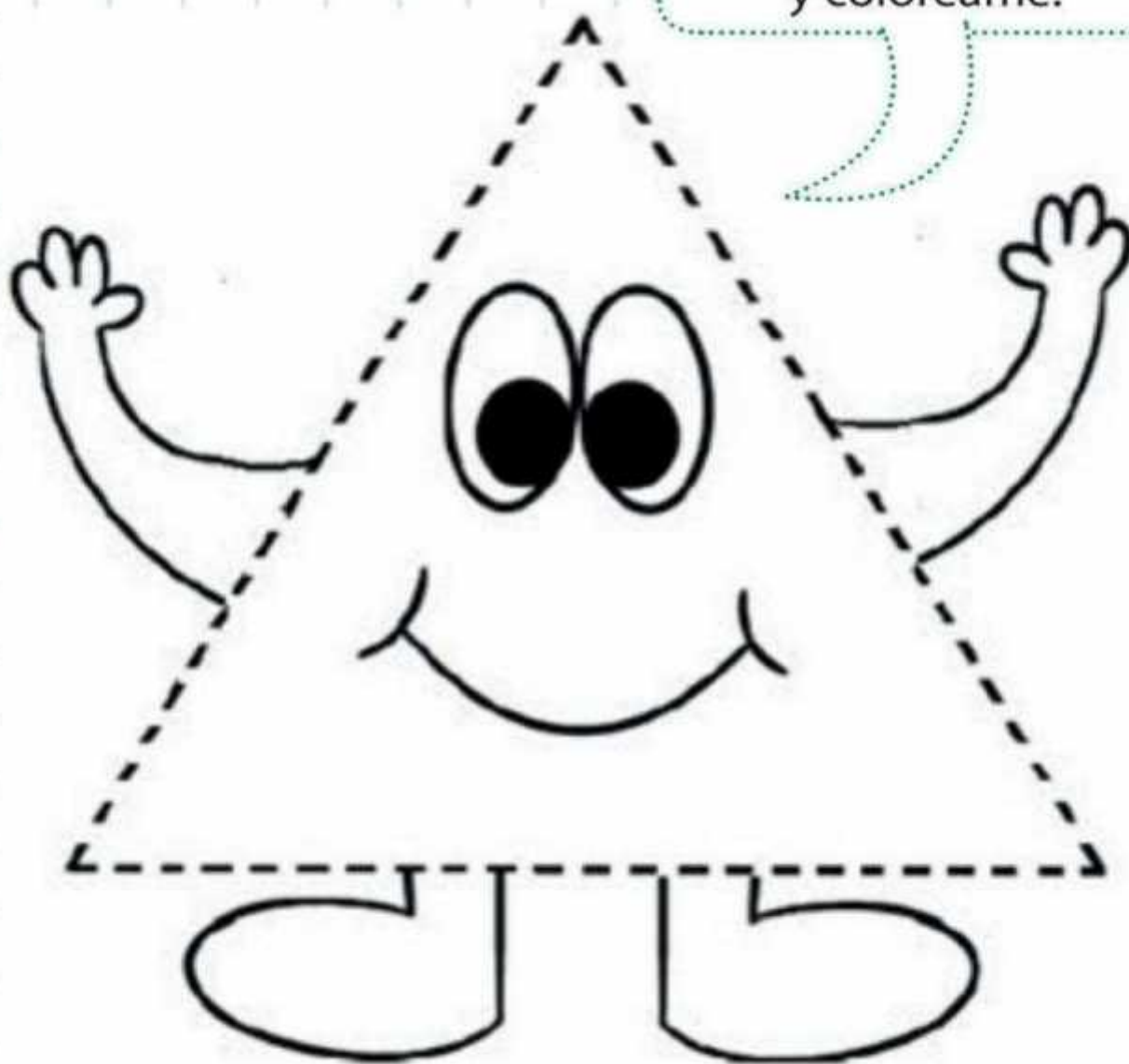



Repasa por los puntos del triángulo con plumón de colores y colorea de amarillo.

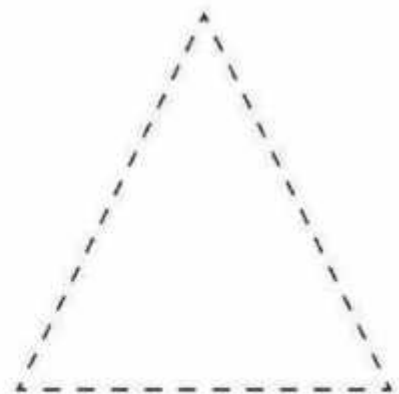
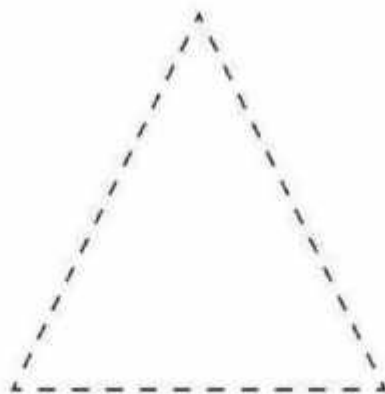
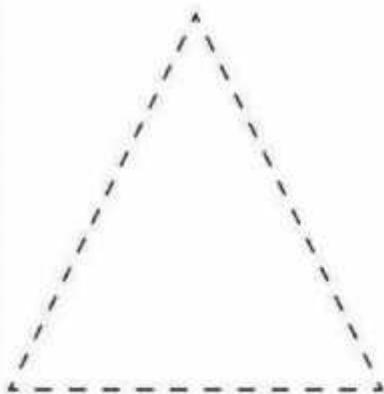
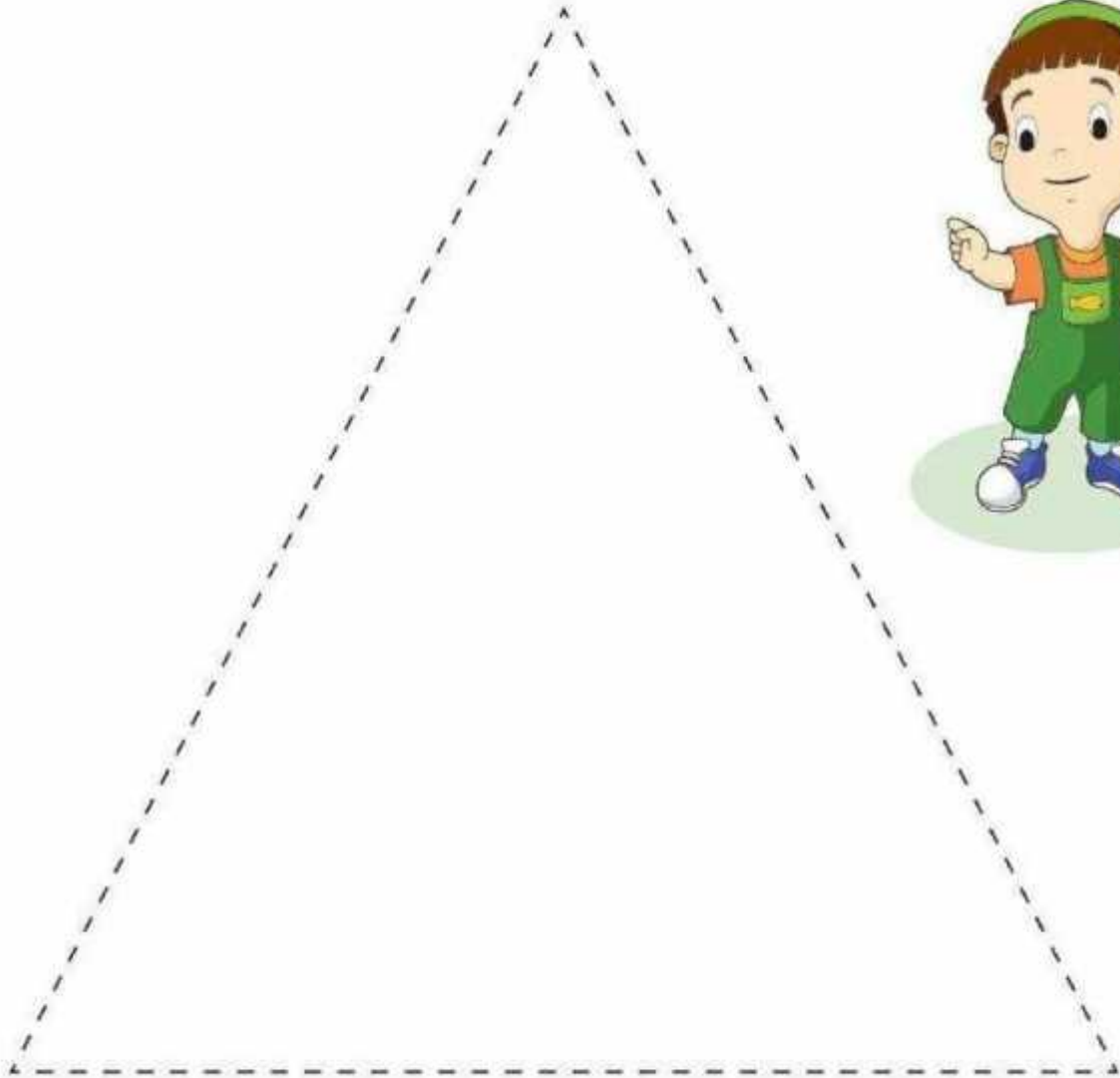

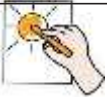

COLOREA EL TREN MAS LARGO DE COLOR AZUL Y DE ROJO EL MAS CORTO

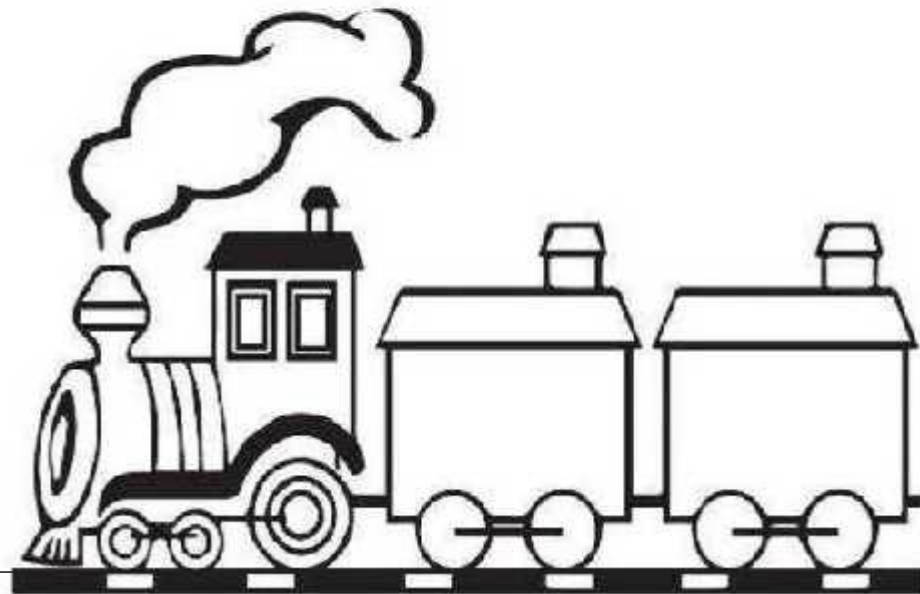
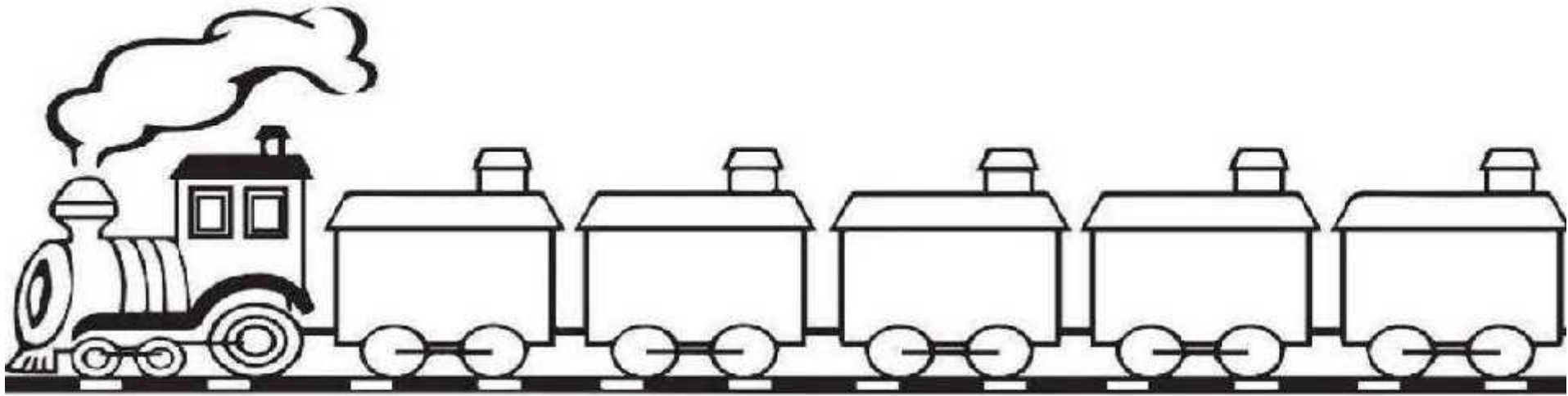

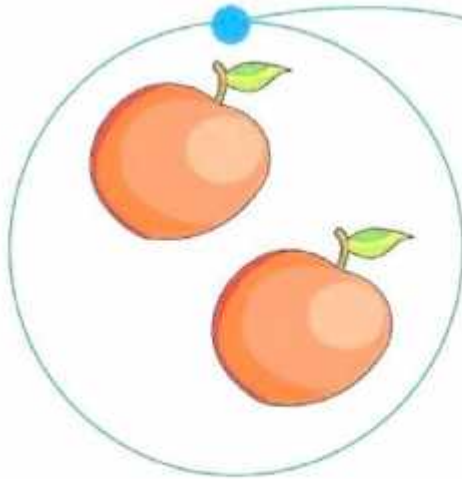

2

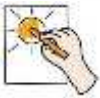

Colorea los conjuntos que tengan dos elementos.

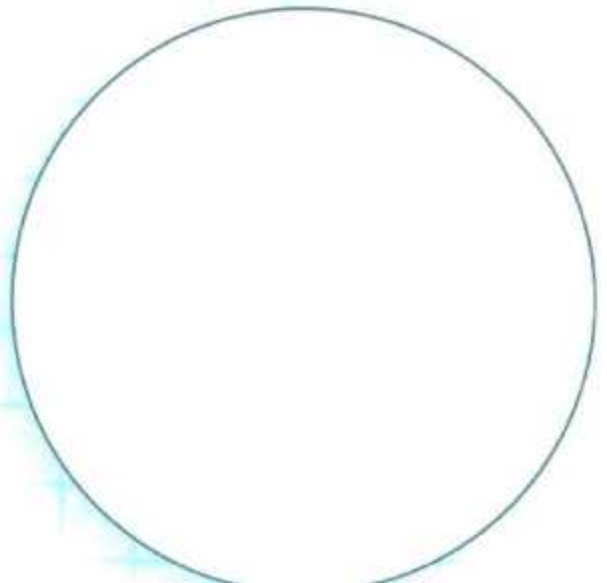
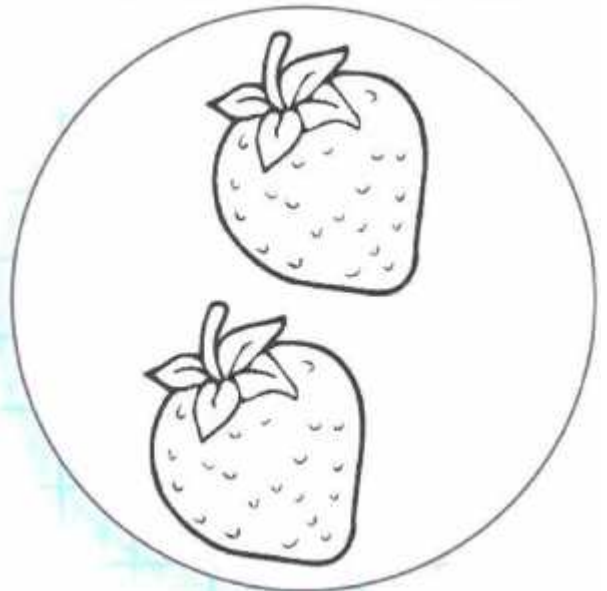
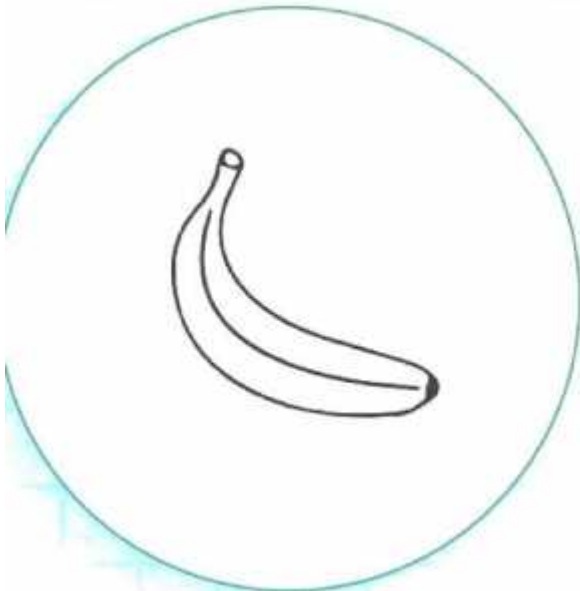



PEGA BOLITAS DE PAPEL EN EL GUSANO LARGO Y COLOREA EL GUSANO CORTO

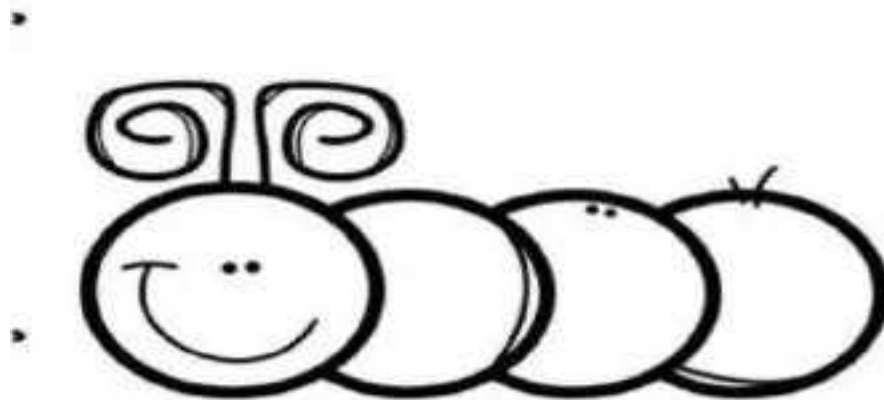
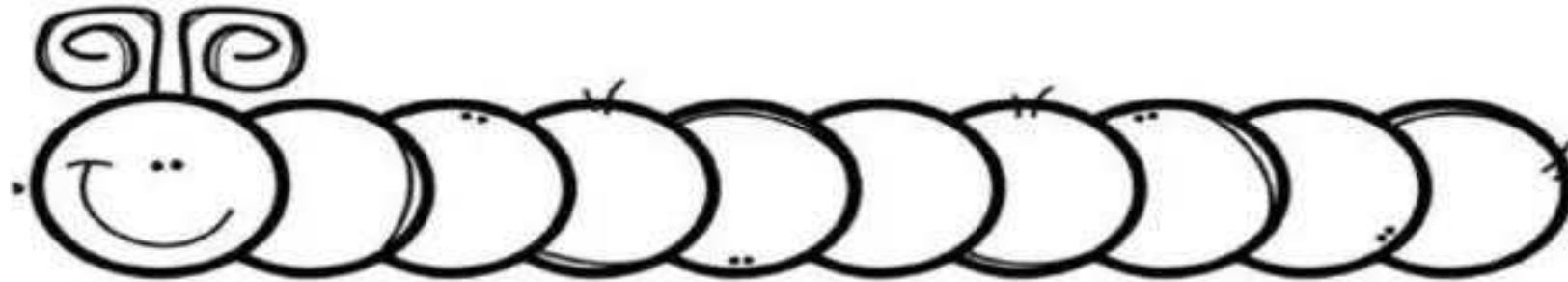

NÚMERO 3

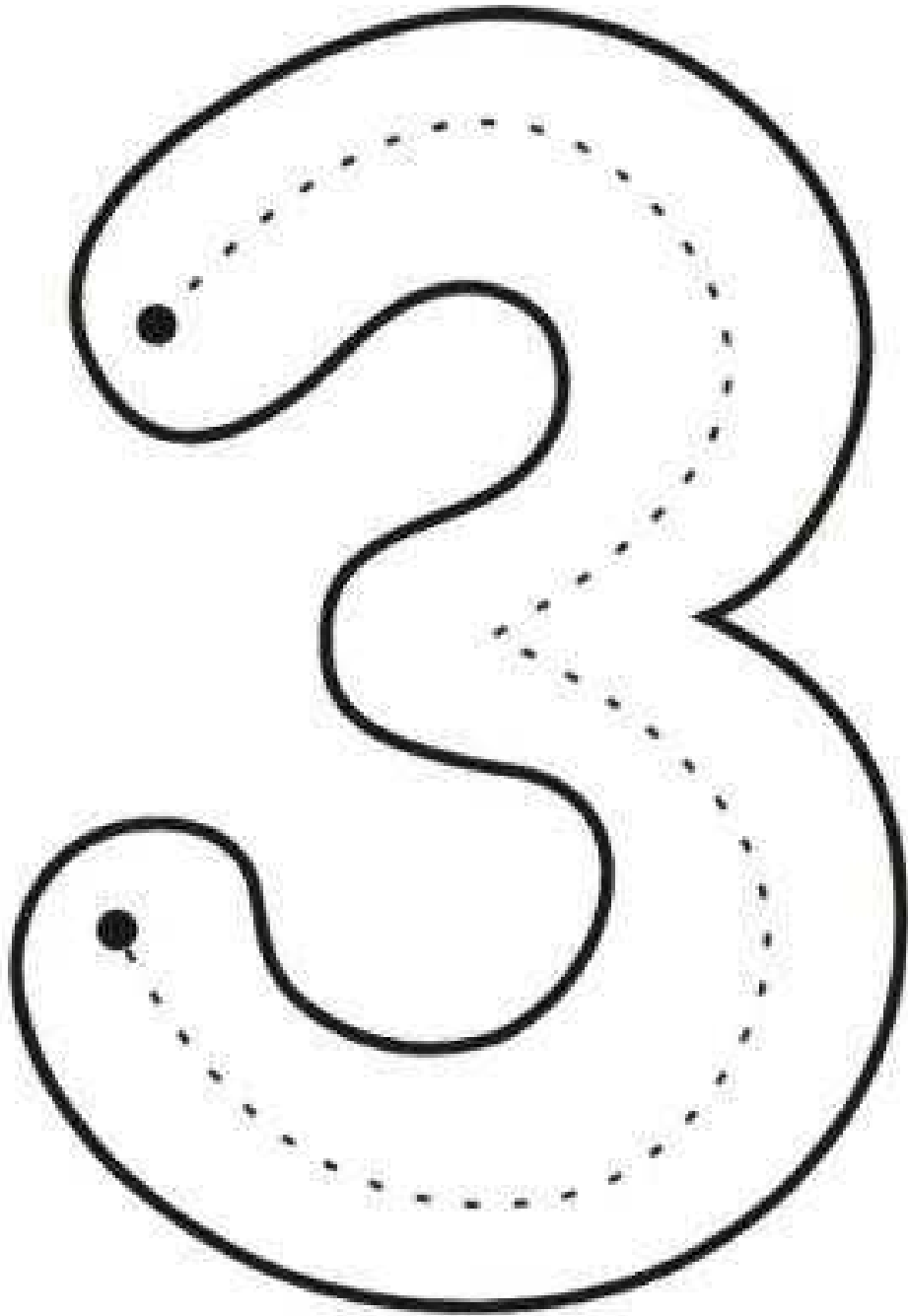
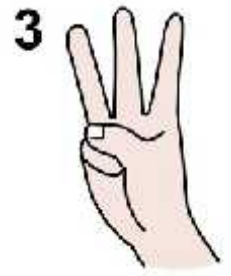

PRESIONA PLASTILINA EN EL NÚMERO SIGUIENDO LOS PUNTOS

¿QUÉ NÚMERO ES?

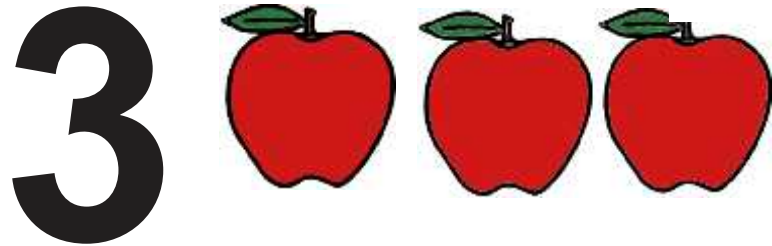
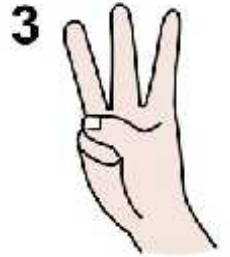

TRES



CÓMO SE ESCRIBE? PASA TU LÁPIZ POR EL PLUMÓN AMARILLO



REPASA POR LAS LÍNEAS PUNTEADAS EL NÚMERO 3

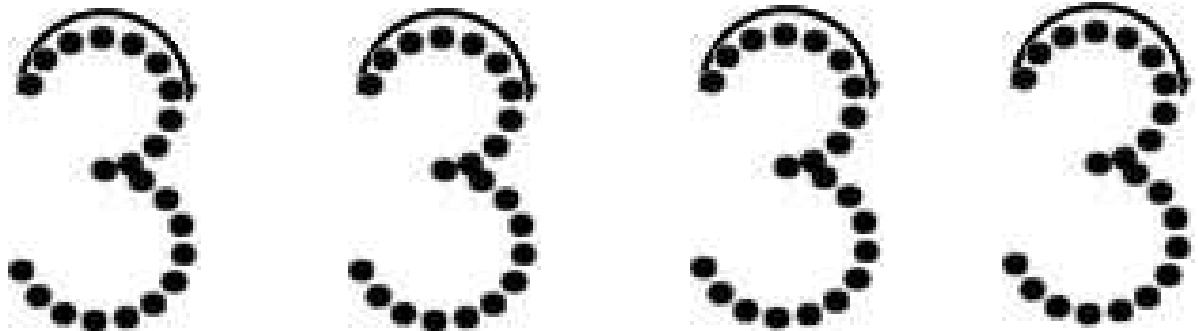

¿QUÉ NÚMERO ES?

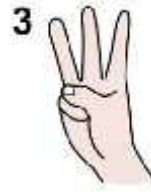

3

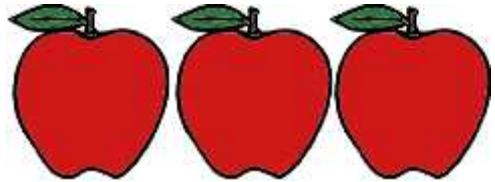
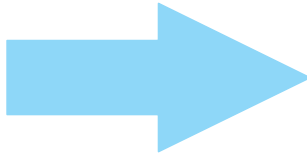

PALABRA

TRES



SÍLABAS

DA PALMADAS ,DE ACUERDO A LAS SÍLABAS DE LA PALABRA

TRES



ESCRITURA TRAZA EL NÚMERO 3

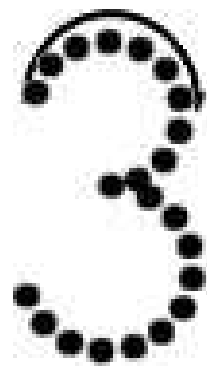
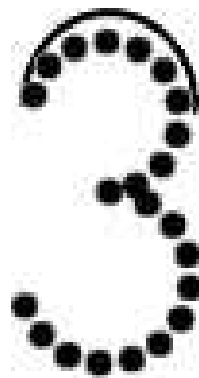
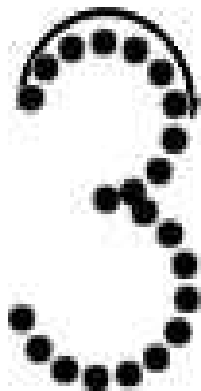
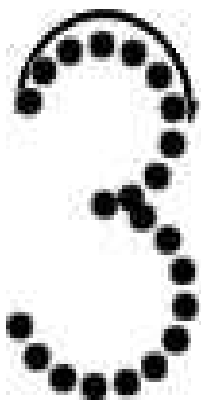



TRES

3



TRES



COLOCA BOLITAS DE PLASTILINA SEGÚN LA CANTIDAD QUE SE TE INDICA

3



Repasa con plumón el número 3 y colorea contando los patos.

3





RODEA EL NÚMERO 3



3

2

3

2

3

2

1

1

3

1

2

3



UNE CADA NÚMERO CON SU CANTIDAD

2

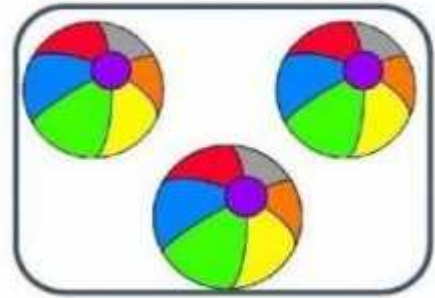

3

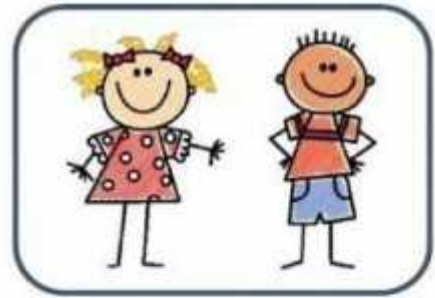

2



3



1





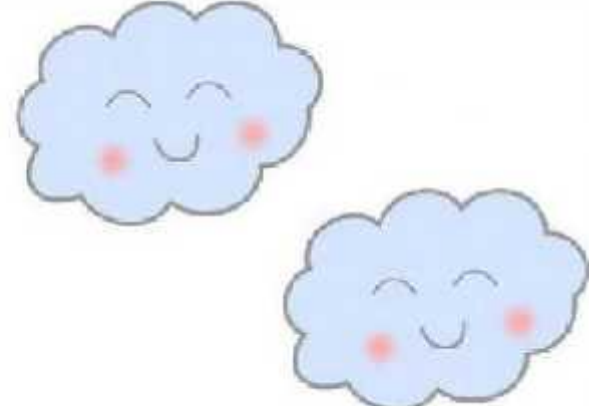

CUENTA LOS DIBUJOS Y SEÑALA EL NÚMERO QUE CORRESPONDE A CADA CASO

		
1	3	2

		
3	1	2

		
1	2	3

		
3	2	1



Embolilla papel por las líneas del número 3 y colorea los lápiz.

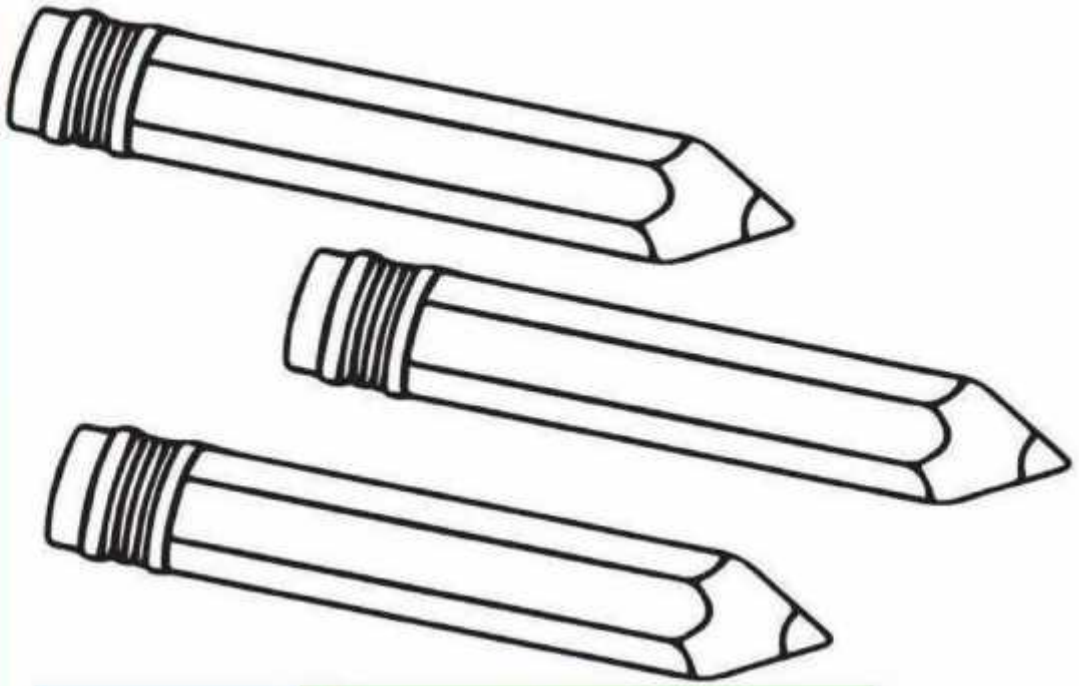
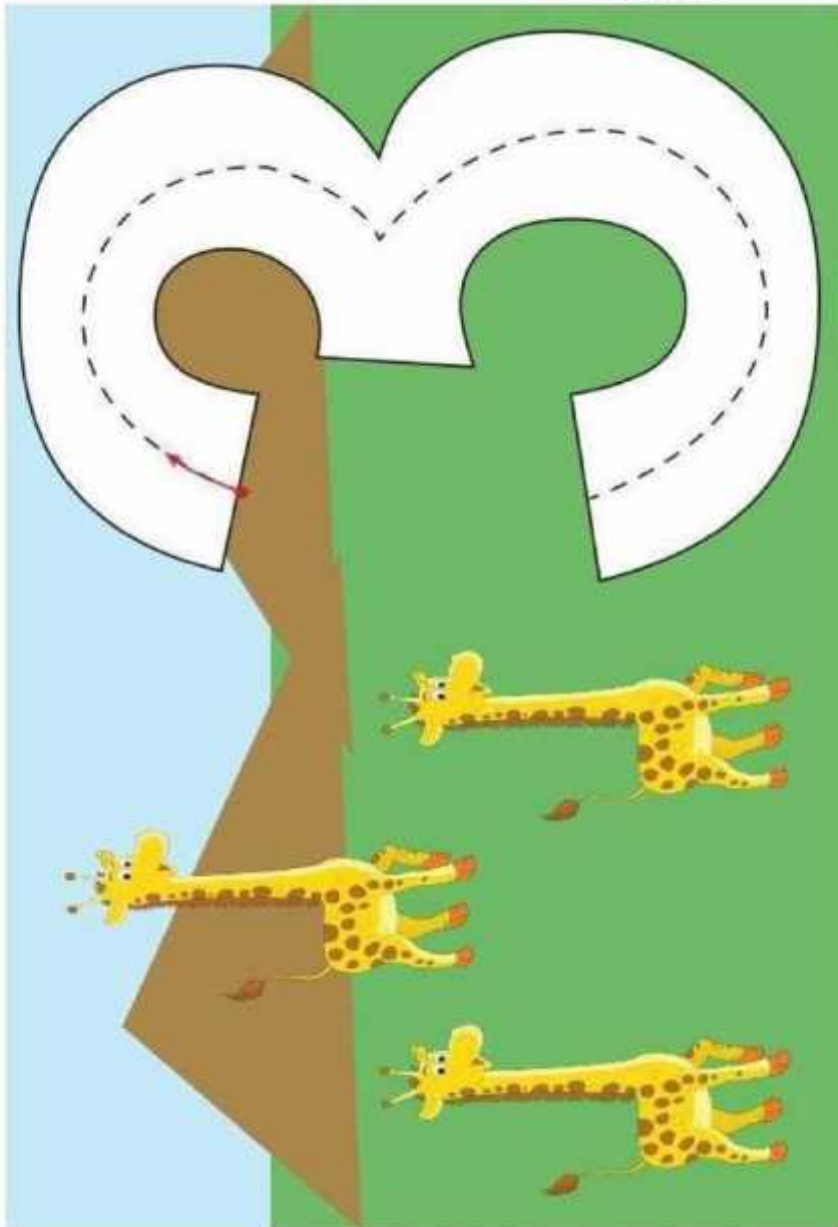

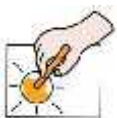

Colorea según indica los números.

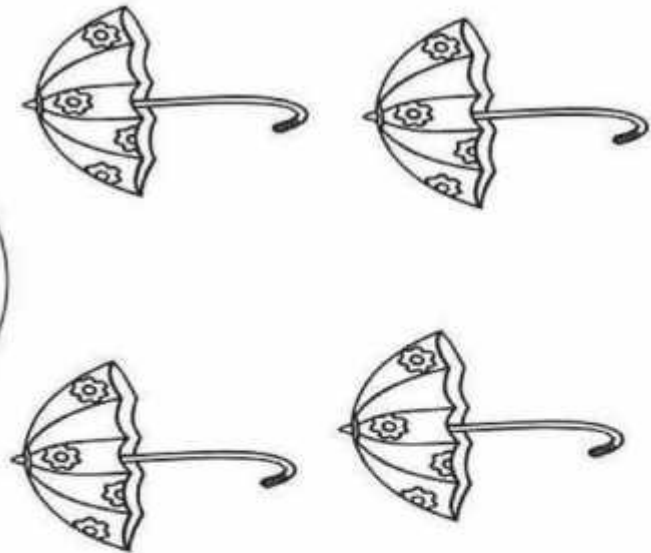
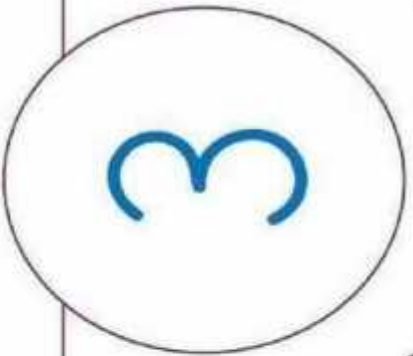
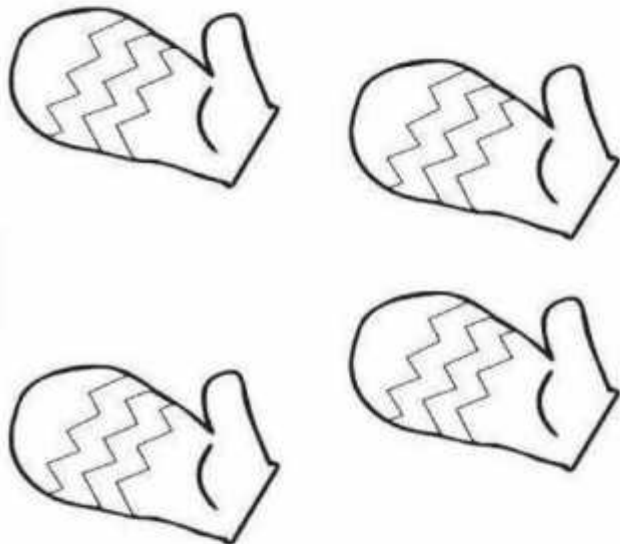
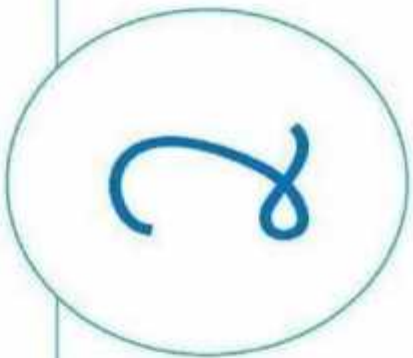
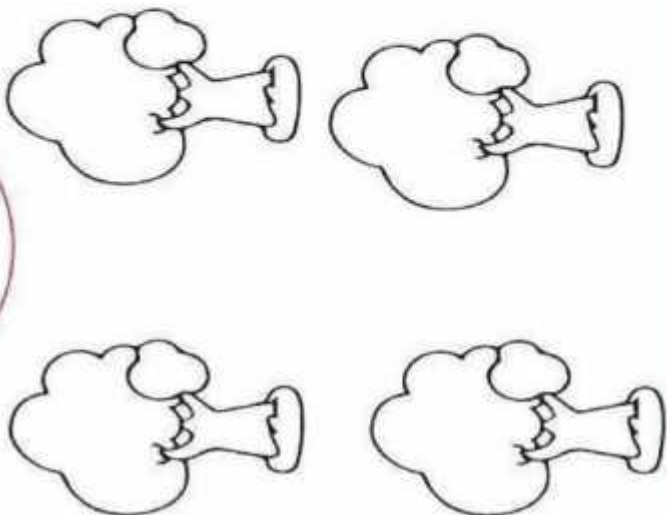

UNE  LOS NÚMEROS 1 2 3





LLENO-VACÍO



RODEA CON UN CÍRCULO LA ESTANTERIA QUE ESTÁ LLENA Y MARCA CON X LA QUE ESTÁ VACÍA



LLENO-VACÍO

LLENA DE FIDEOS EL FRASCO DE COLOR AMARILLO Y RODEA EL QUE ESTÁ VACÍO

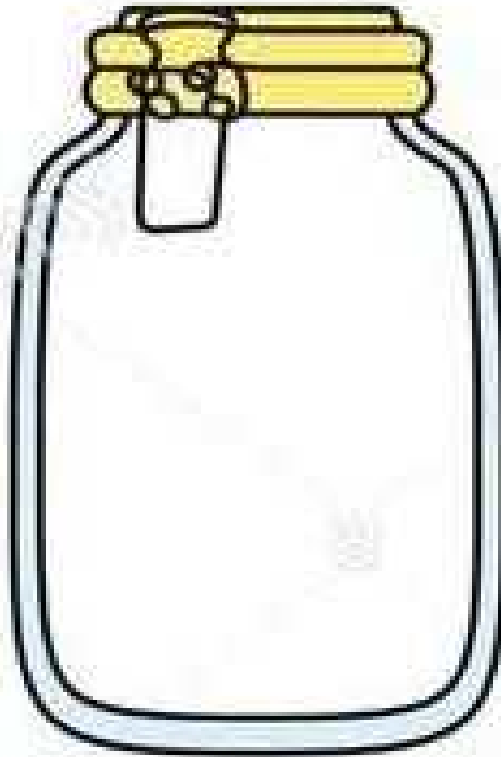



SEÑALA LA PECERA QUE ESTÁ LLENA Y ENCIERRA LA PECERA QUE ESTA VACÍA

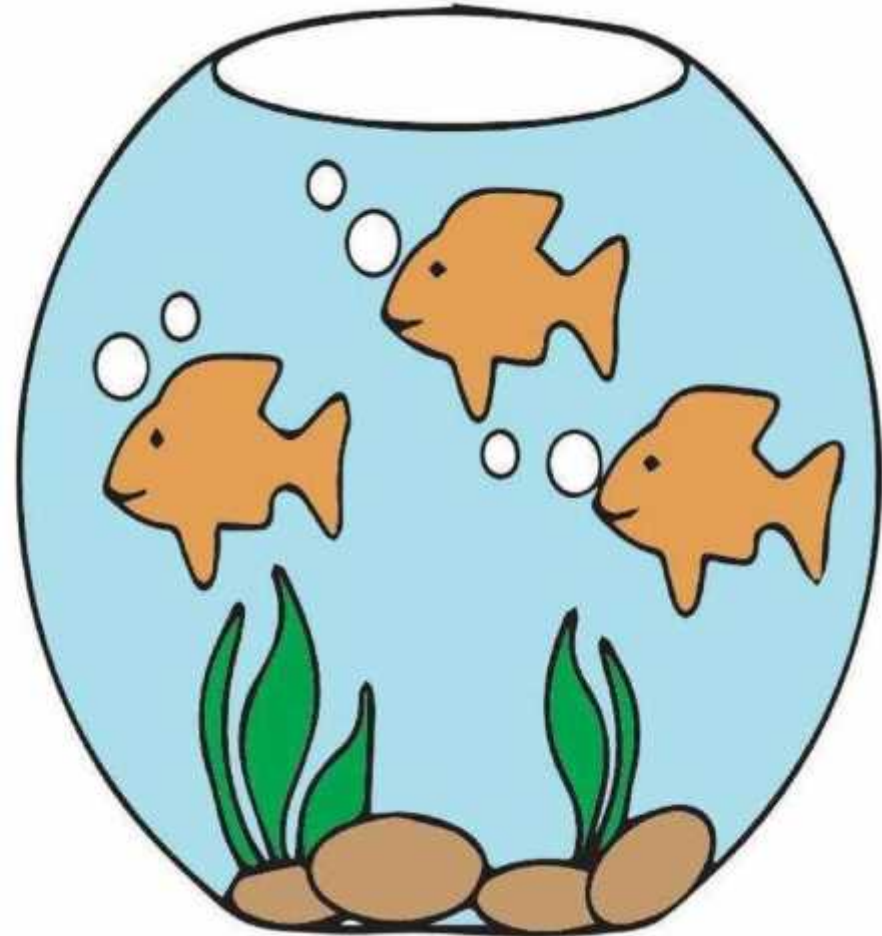
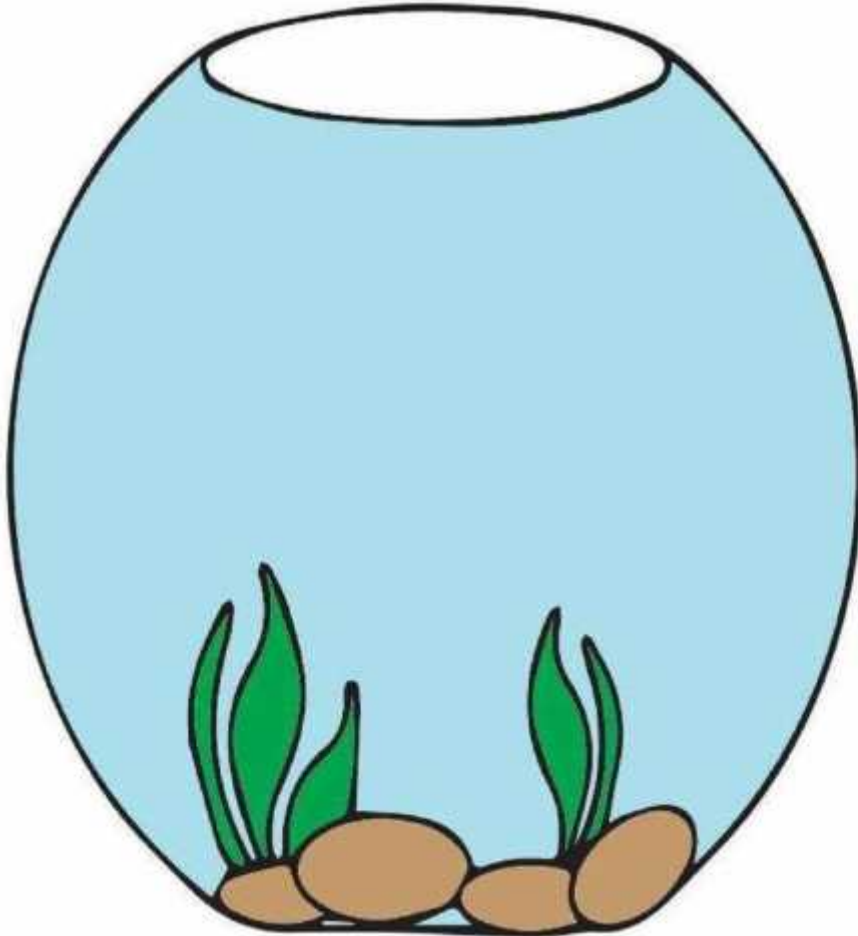

NÚMERO 4

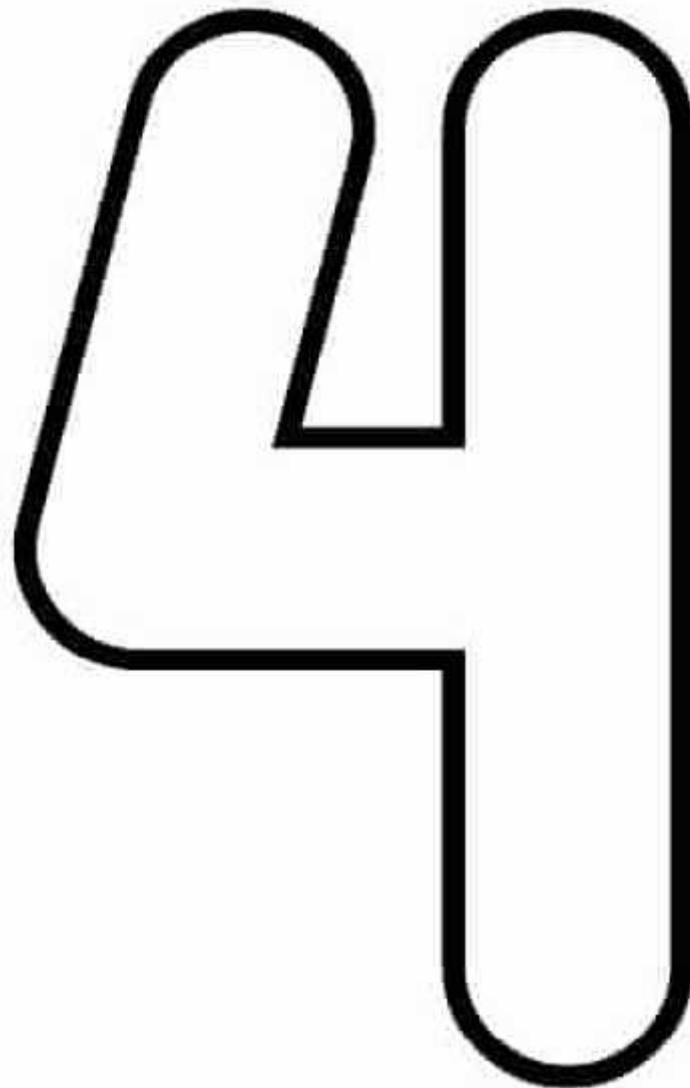

EMBOLILLA PAPEL CREPÉ Y PEGA EN EL NÚMERO 4

¿QUÉ NÚMERO ES?

4

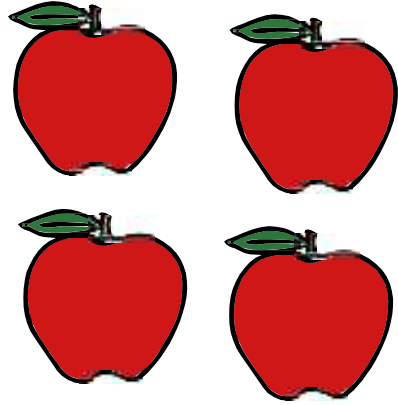
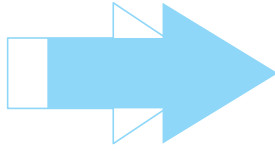

PALABRA

CUATRO



SÍLABAS

DA PALMADAS ,DE ACUERDO A LAS SÍLABAS DE LA PALABRA

CUA

TRO



ESCRITURA

TRAZA EL NÚMERO

4

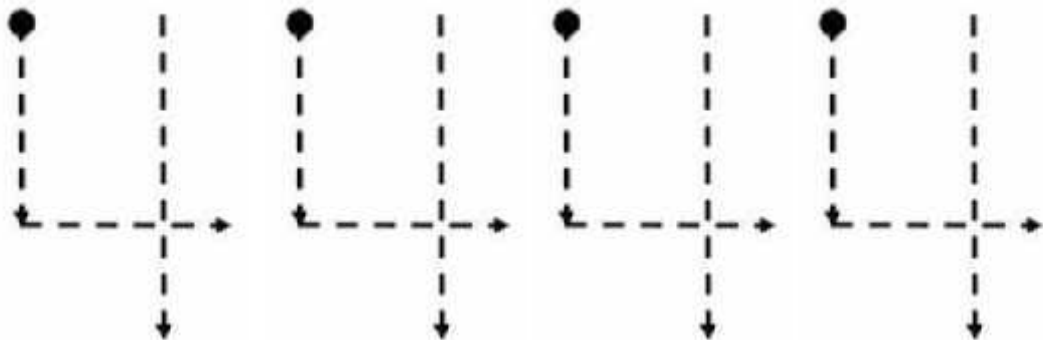

Números del 1 - 4



Reposa cada número y pinta las imágenes contando.

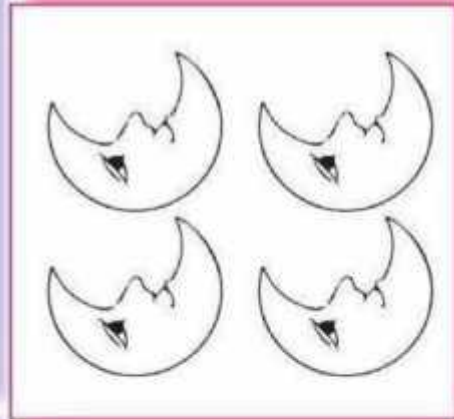
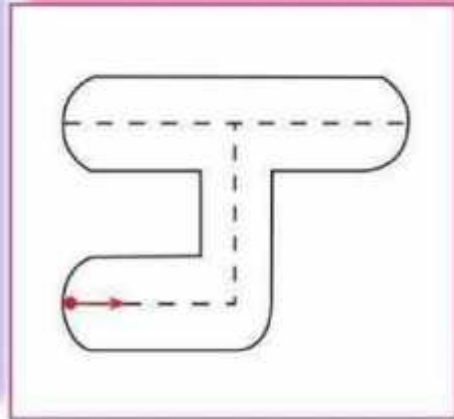
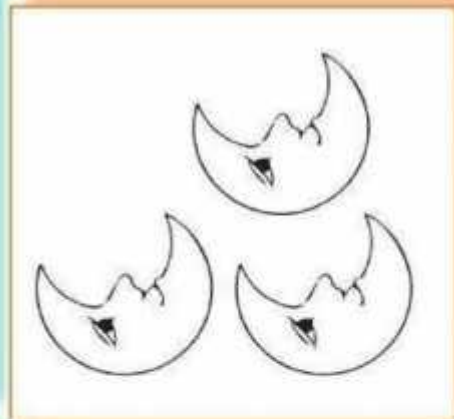
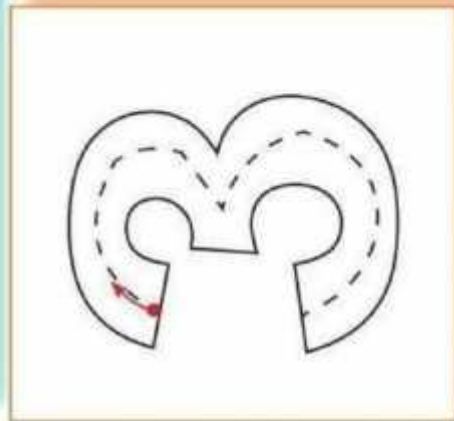
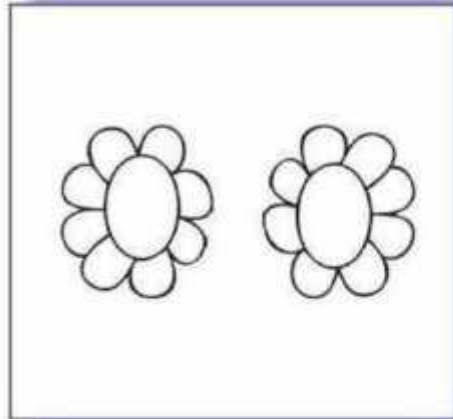
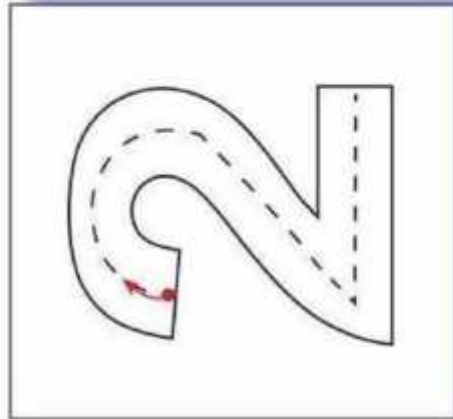
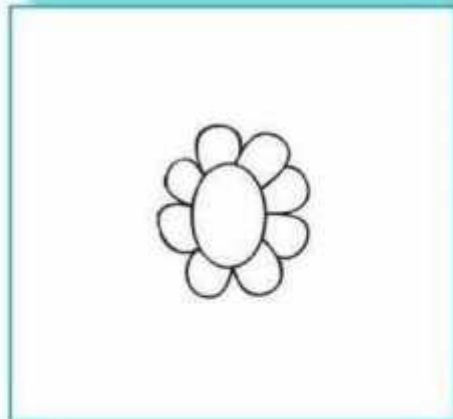
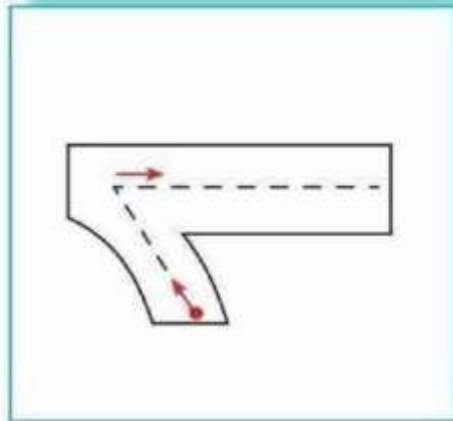

Cerca - Lejos

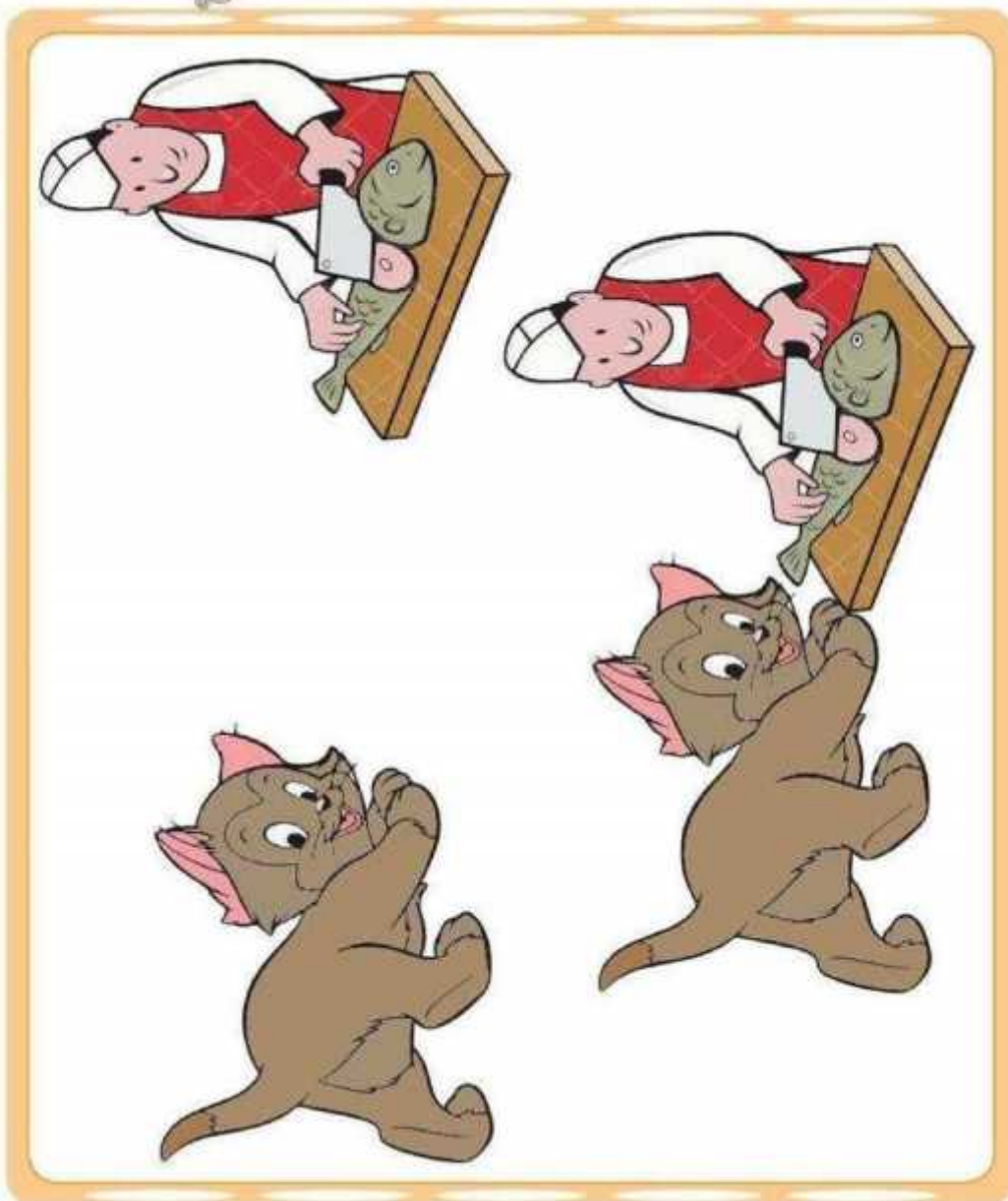

- ◆ Encierra al gato que tiene el pescado cerca.
- ◆ Marca (X) al gato que tiene lejos el pescado.



- ◆ Pega lana en el cabello del payasito grueso.
- ◆ Rasga papel en el sombrero del payasito delgado.

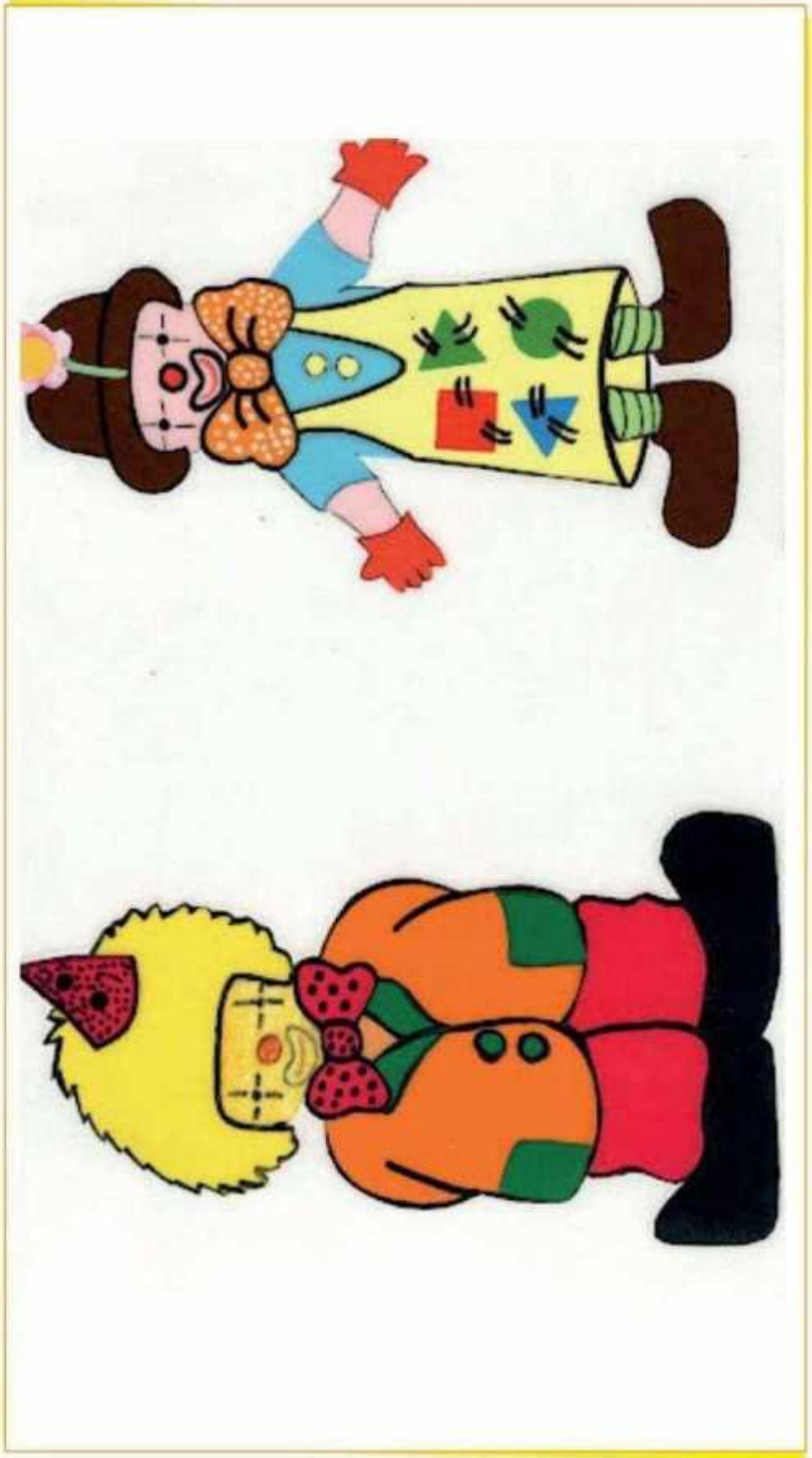

- Espere plastilina por las líneas del número 5.
- Pinta contando los peces .

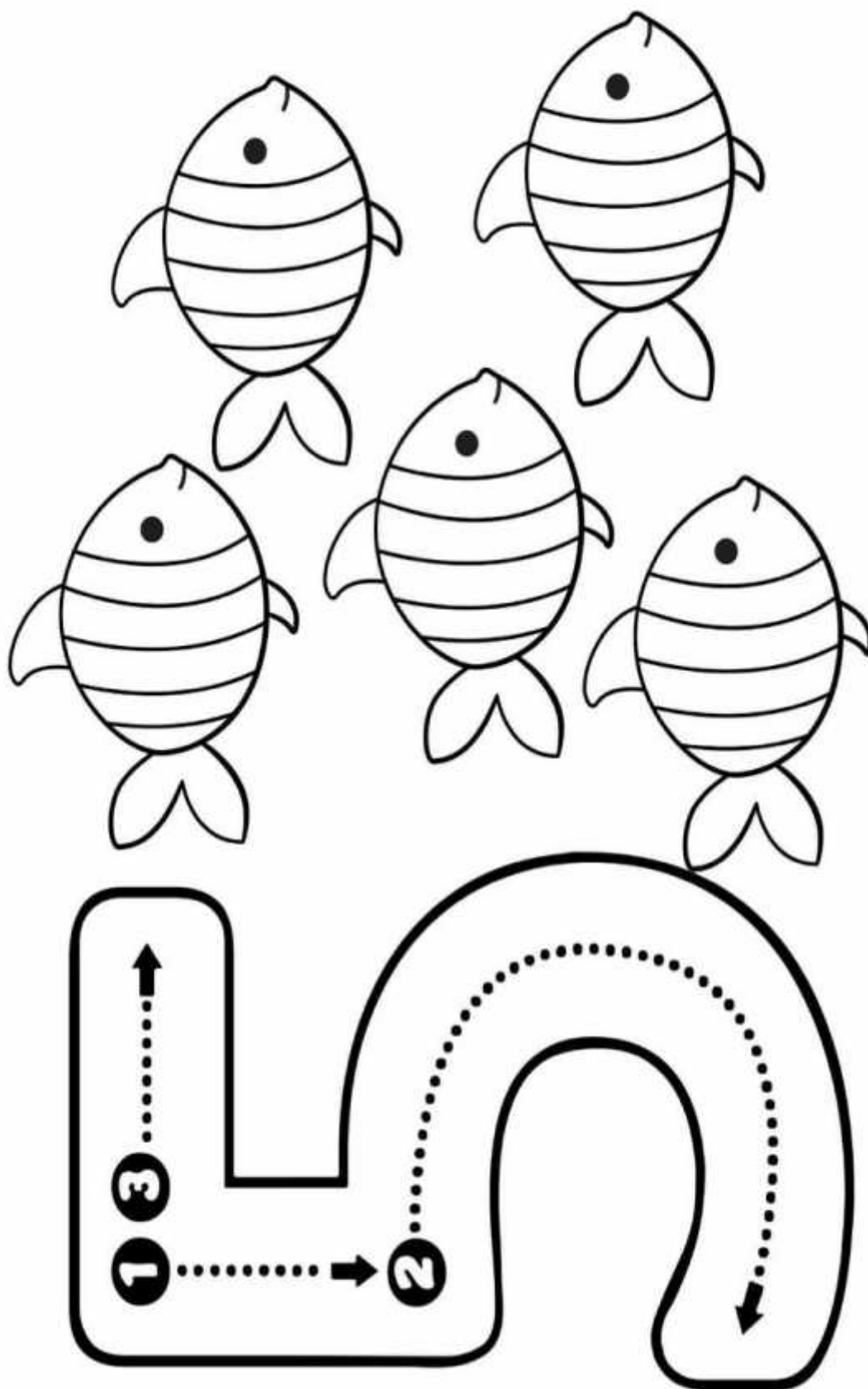



Embolilla papel en el número 5 y repasa los números.
Colorea cada carrito contando.



A large dashed number 5 is positioned at the top of the page for tracing. Below it, five toy cars are arranged in two rows. The top row contains three cars with numbers 1, 2, and 3 on their sides. The bottom row contains two cars with numbers 4 and 5 on their sides. The cars are intended to be colored and used for counting practice.

A vertical column of five dotted number 5s is located on the right side of the page, designed for tracing practice. Each number has a small red dot at the top left corner to indicate the starting point for writing.

Grueso - Delgado



- ◆ Colorea el lápiz grueso de color azul.
- ◆ Pinta el lápiz delgado de color rojo.

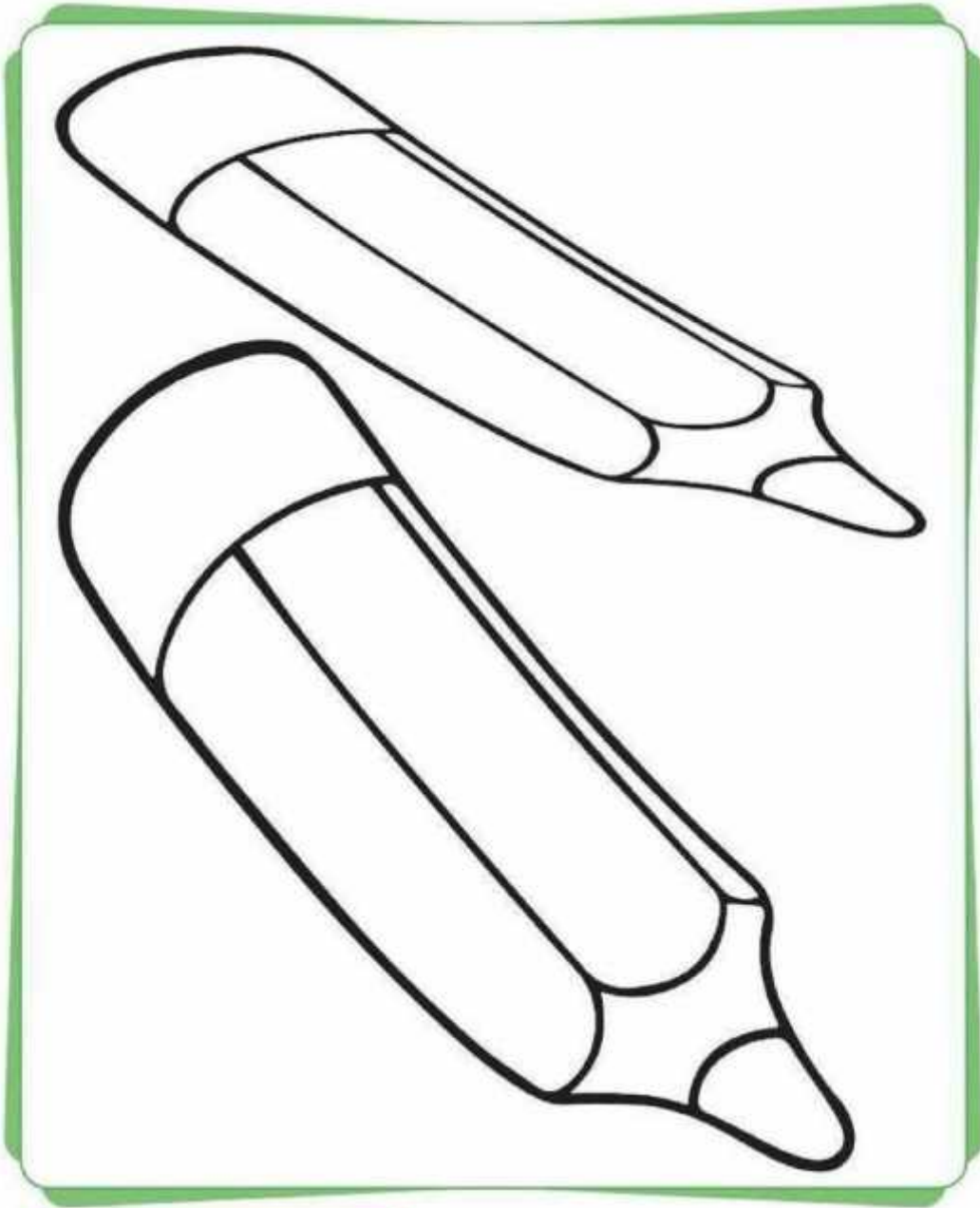

Verde

Con tu dedo índice pinta con tempera verde la mancha.

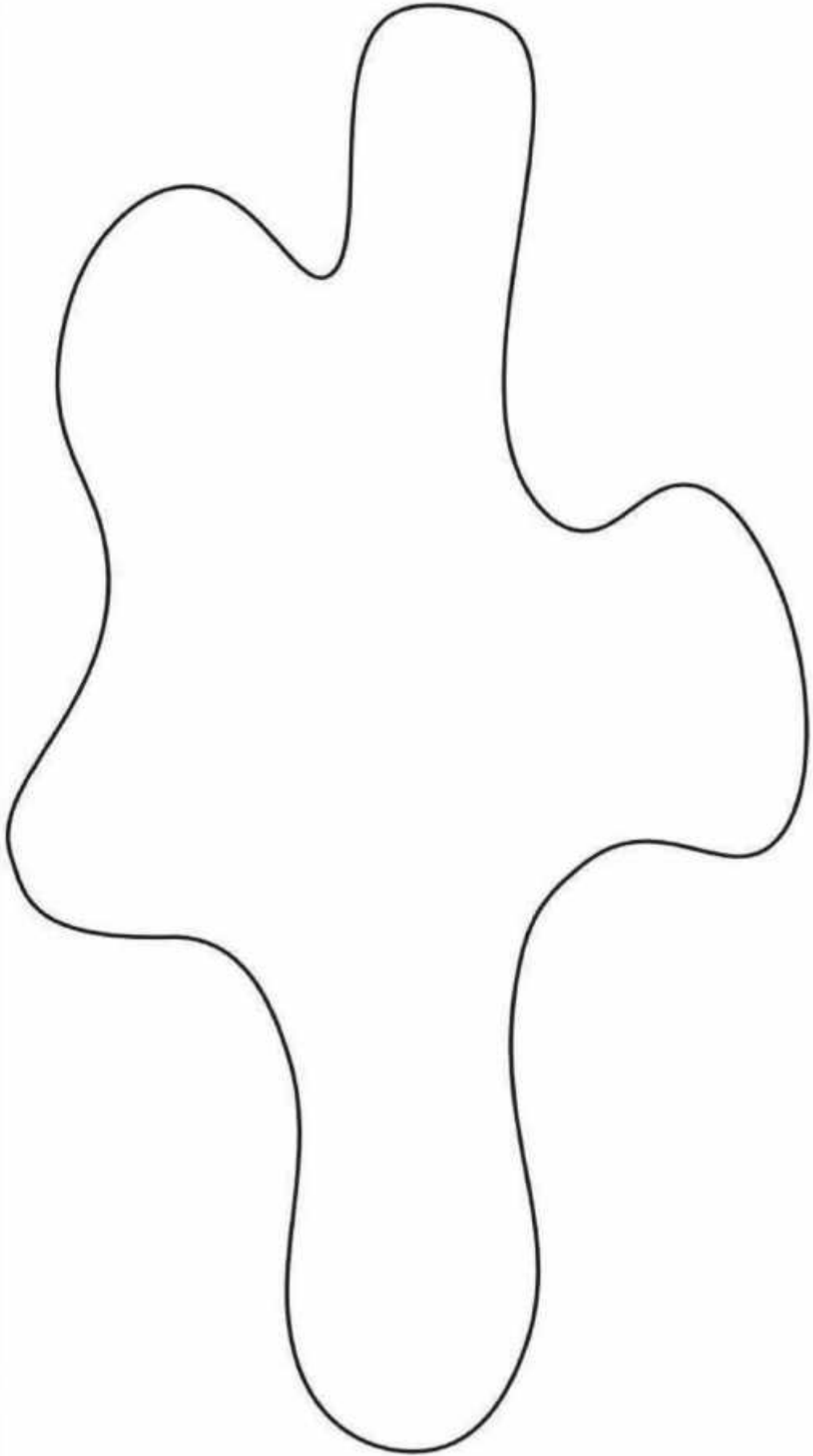

Verde



Rasga papel lustre verde y pega dentro del globo.

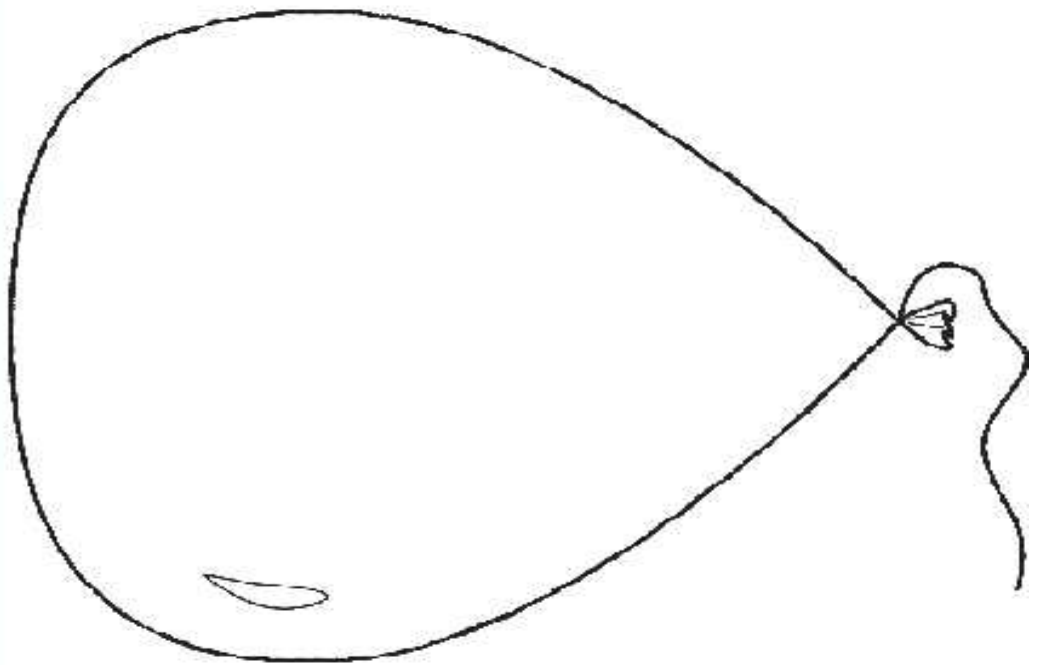

Número 6

Pega lentejuelas en los puntos y colorea contando las fresas.

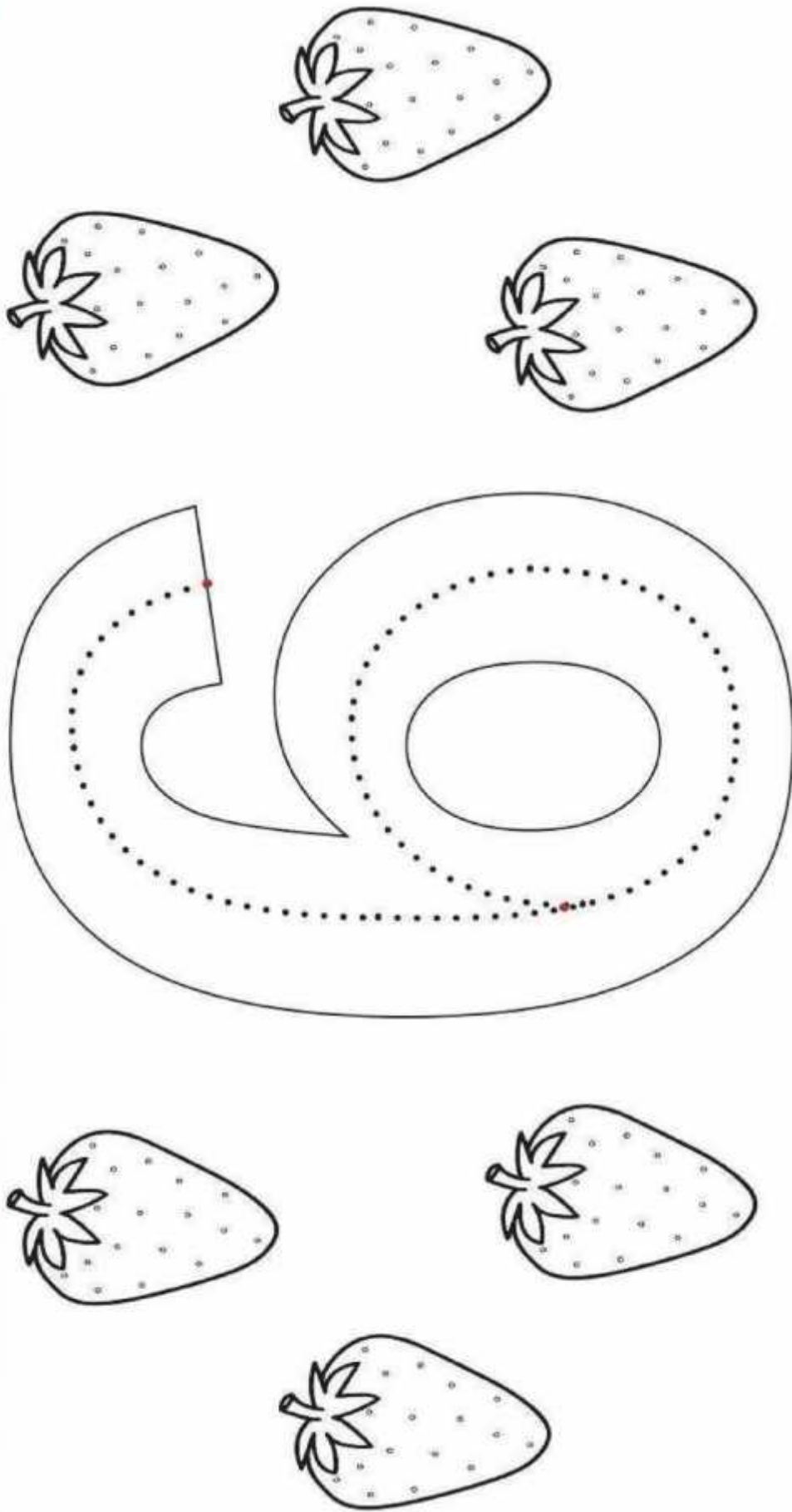



Colorear seis autos.
Repasa el número 6.

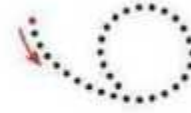
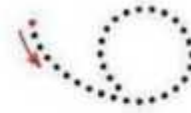
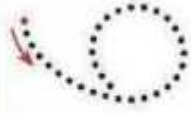
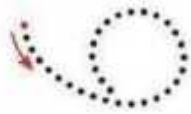
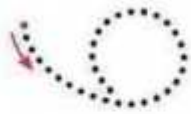
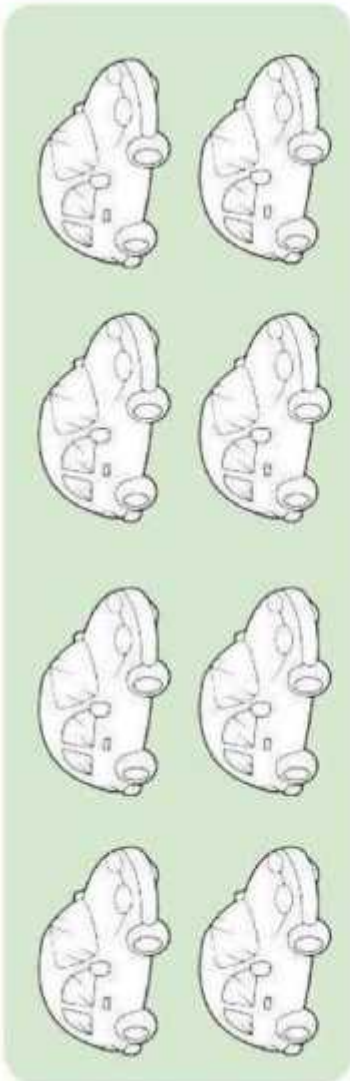

Primero = Último



Pinta al niño que está primero y marca (X) al niño que está último.

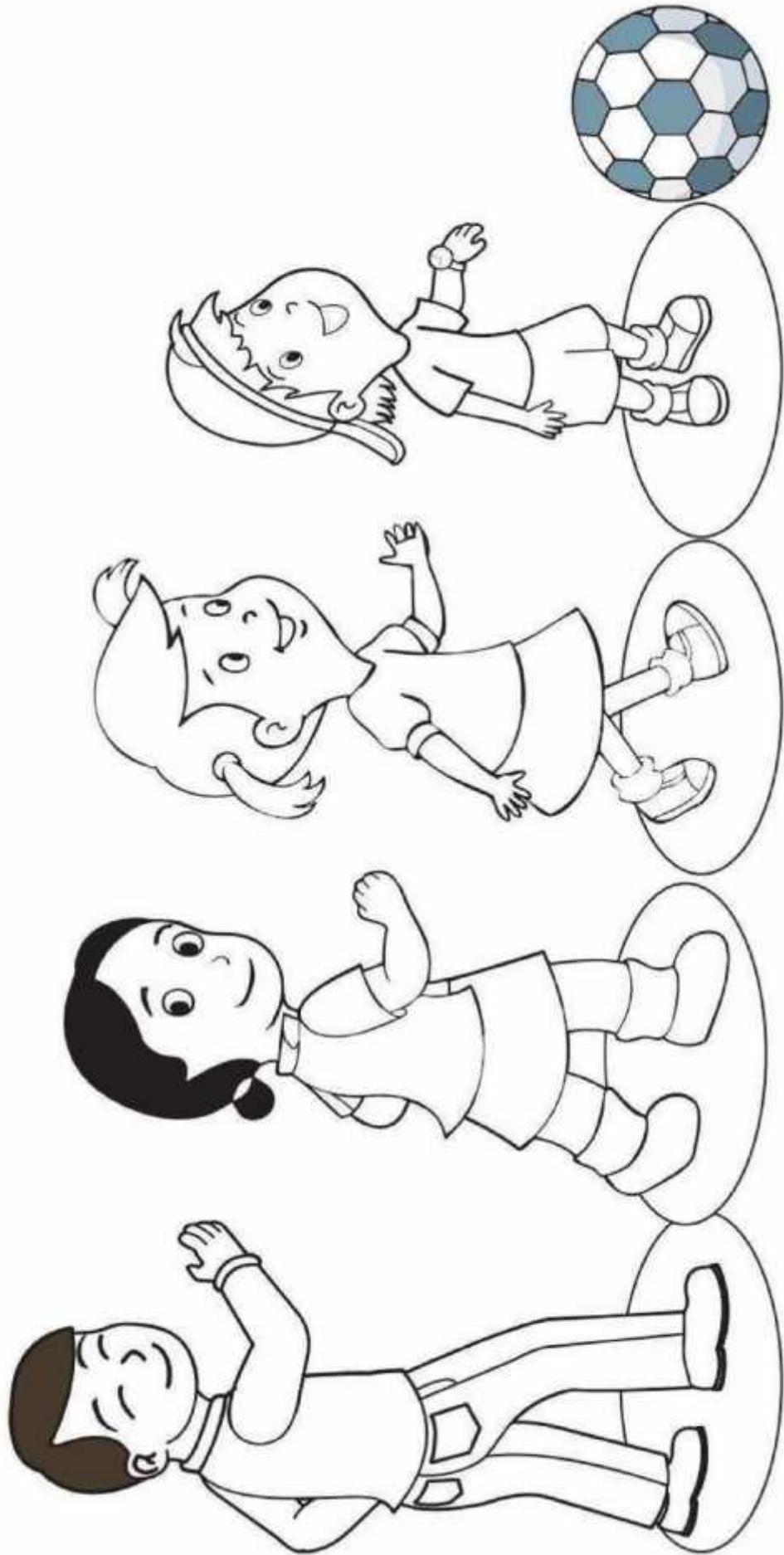

PRIMERO - ÚLTIMO

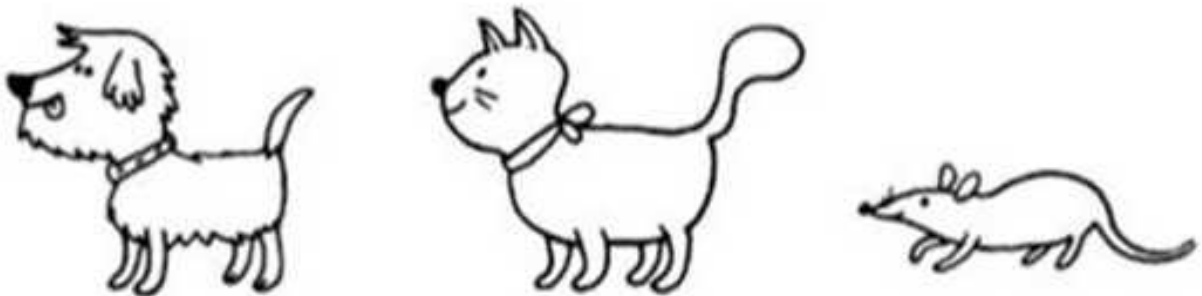
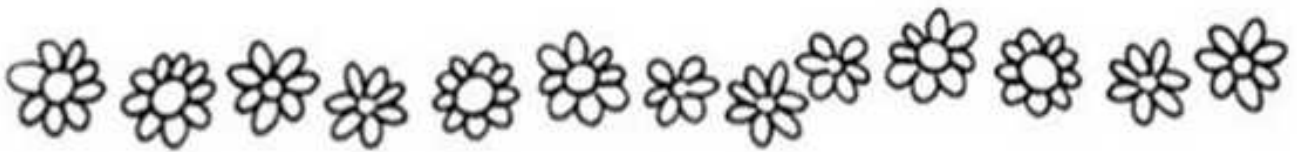
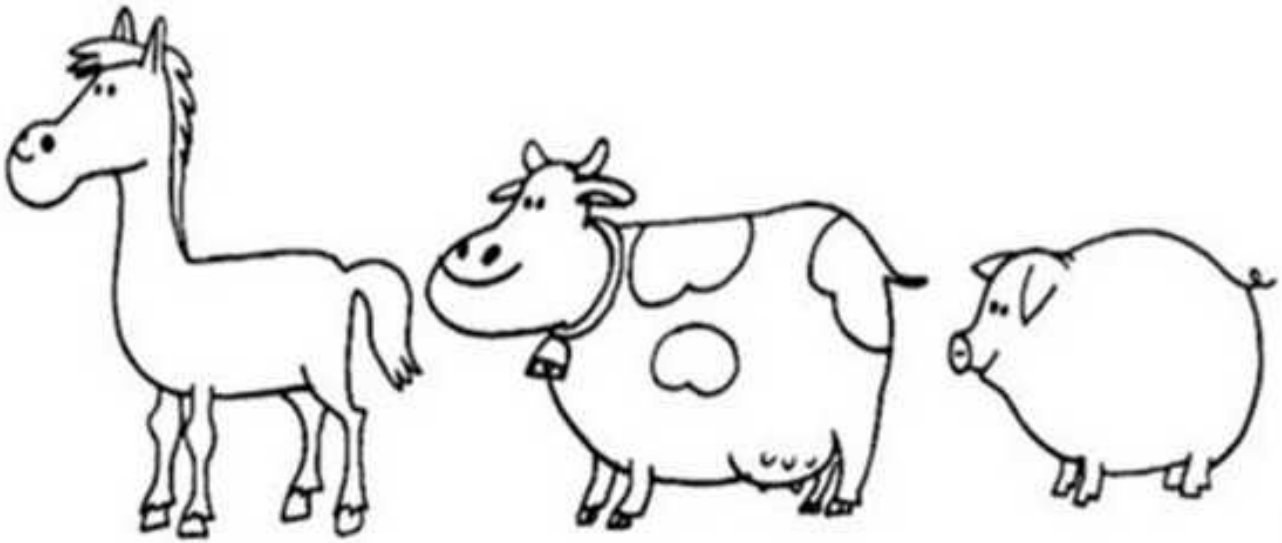

COLOREA CON CRAYOLA DE COLOR MARRÓN EL ANIMALITO QUE VA PRIMERO EN CADA FILA Y DE COLOR ROSADO EL ANIMALITO QUE VA AL ÚLTIMO.

Ordinales



Colorea al tercer niño de la fila.

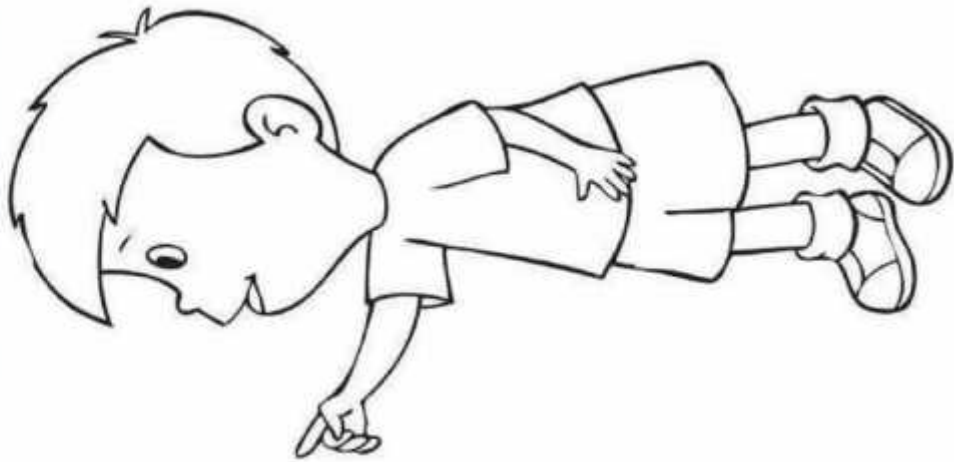
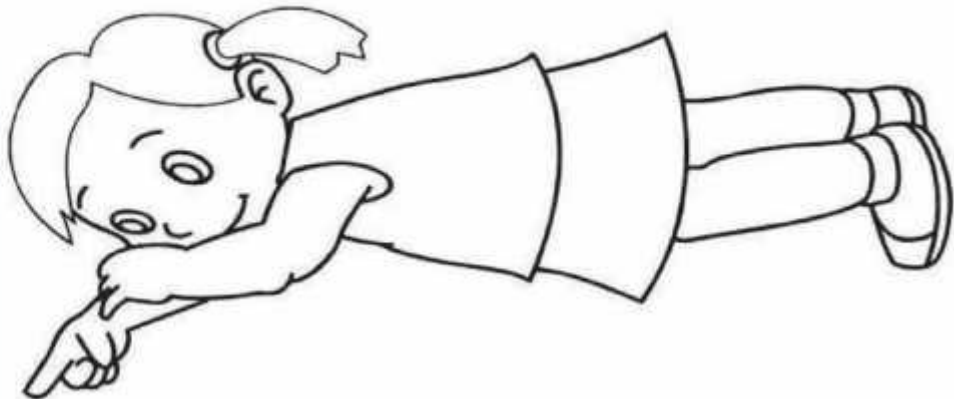
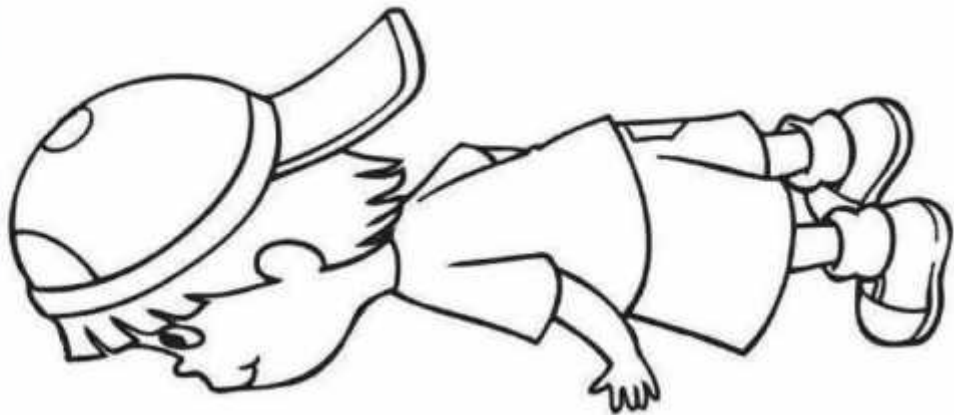
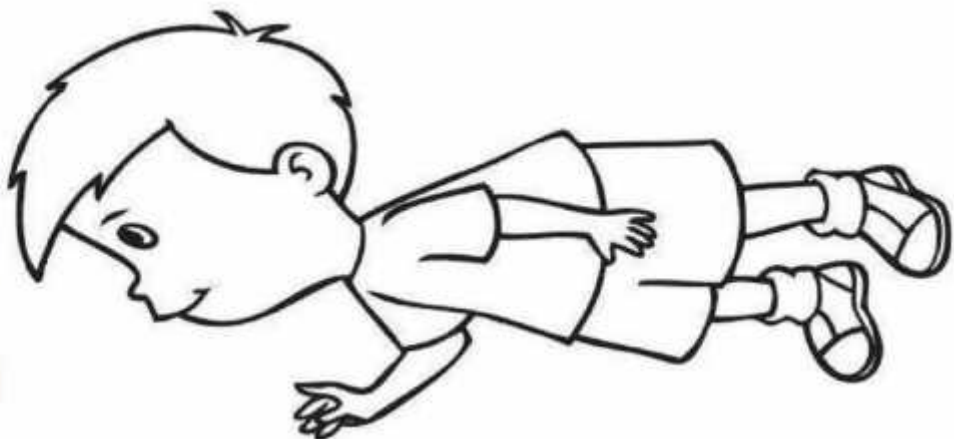

¡HAGAMOS UNA FILA!

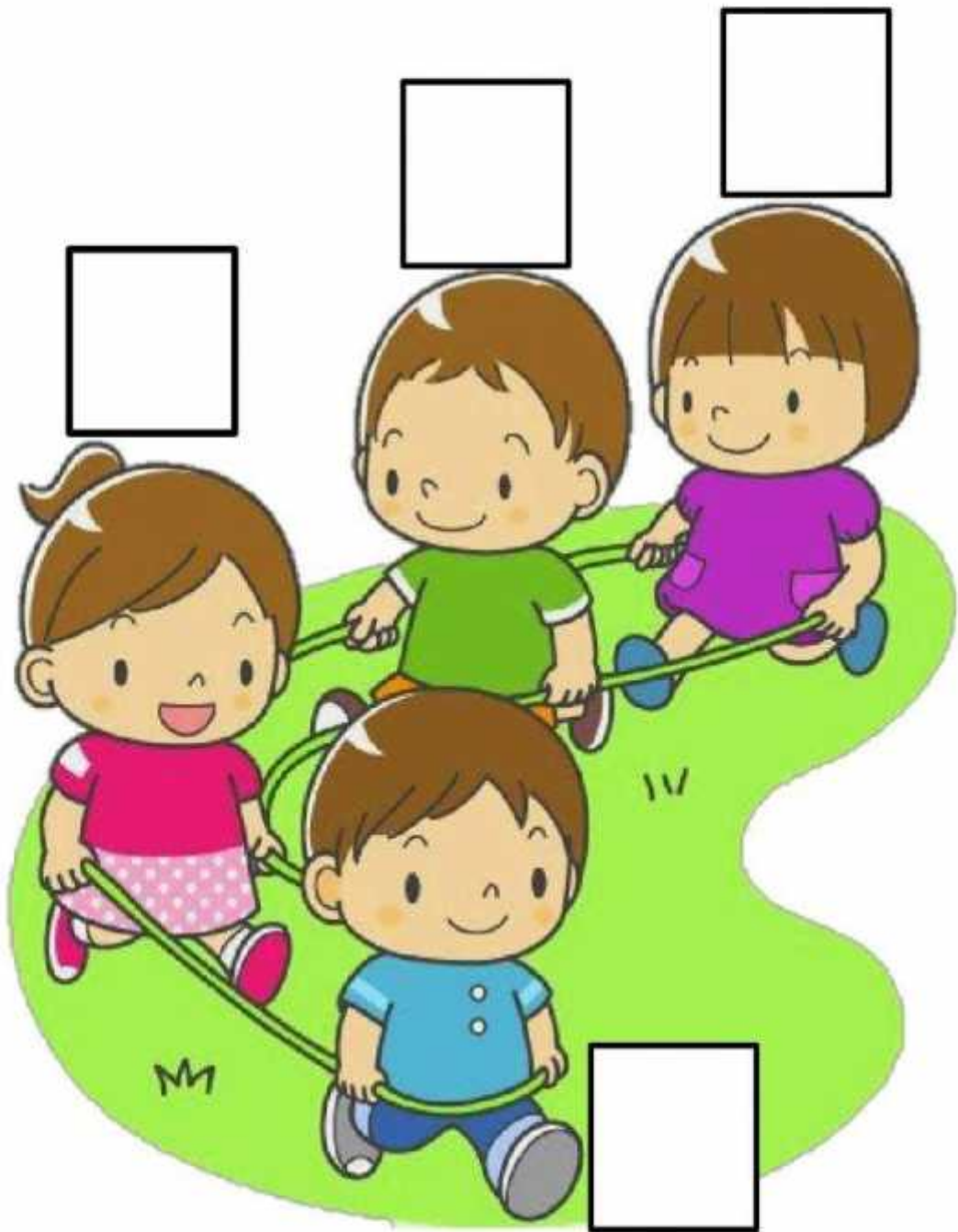

2°

1°

3°

4°

Observa la posición que ocupa cada niño en la fila, luego arrastra el número ordinal según corresponda.

Hola "Soy el rectángulo"



Pinta el rectángulo.

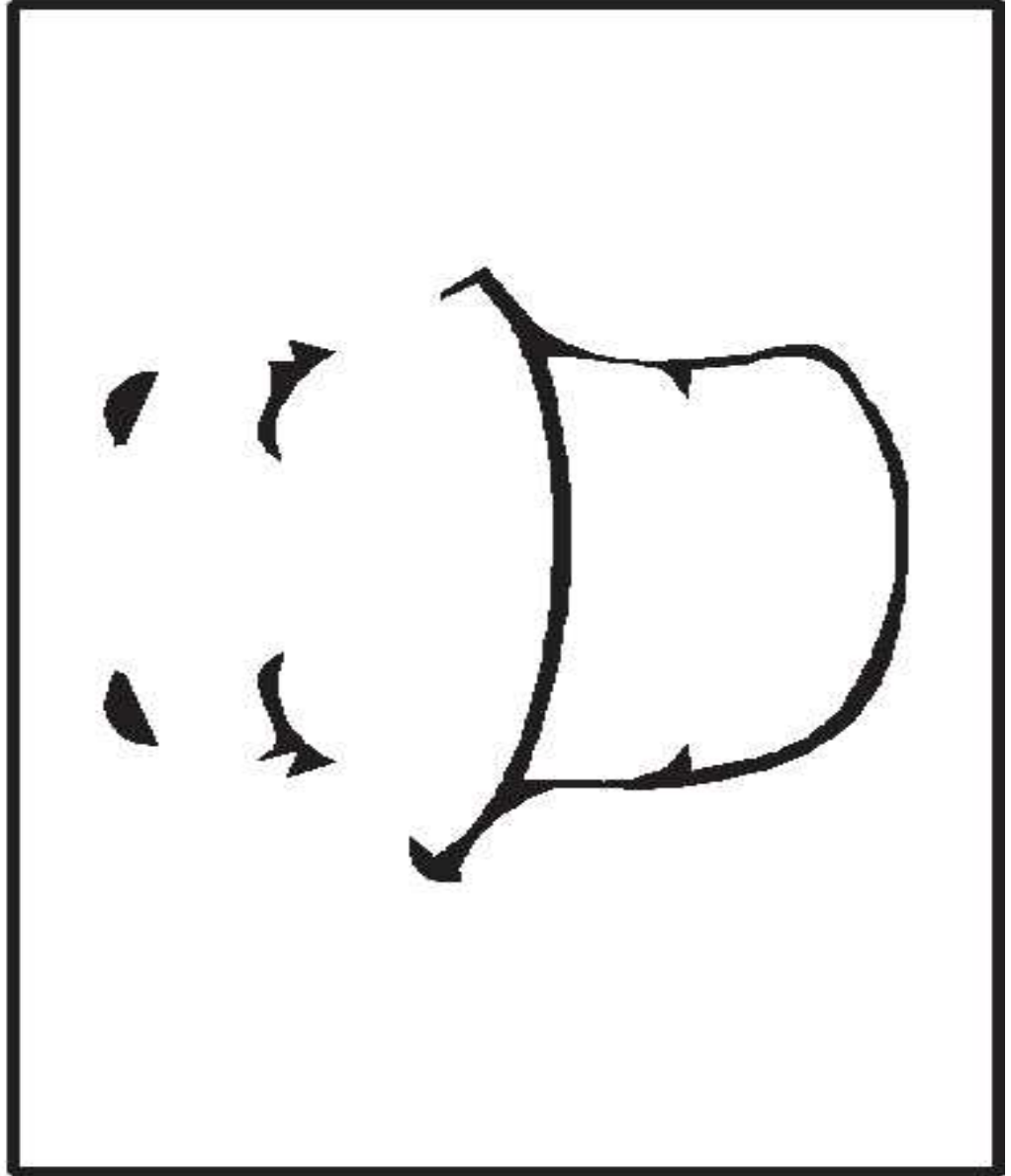

Rectángulo



Pega serpentina al borde del rectángulo. Repasa los rectángulos y pinta de colores.

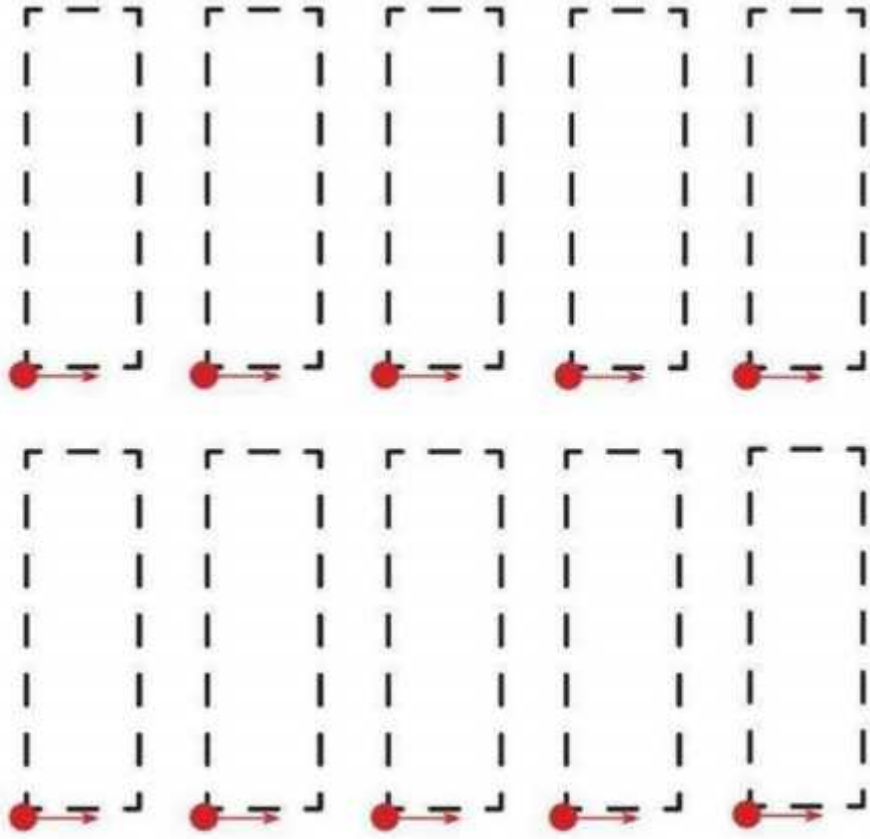
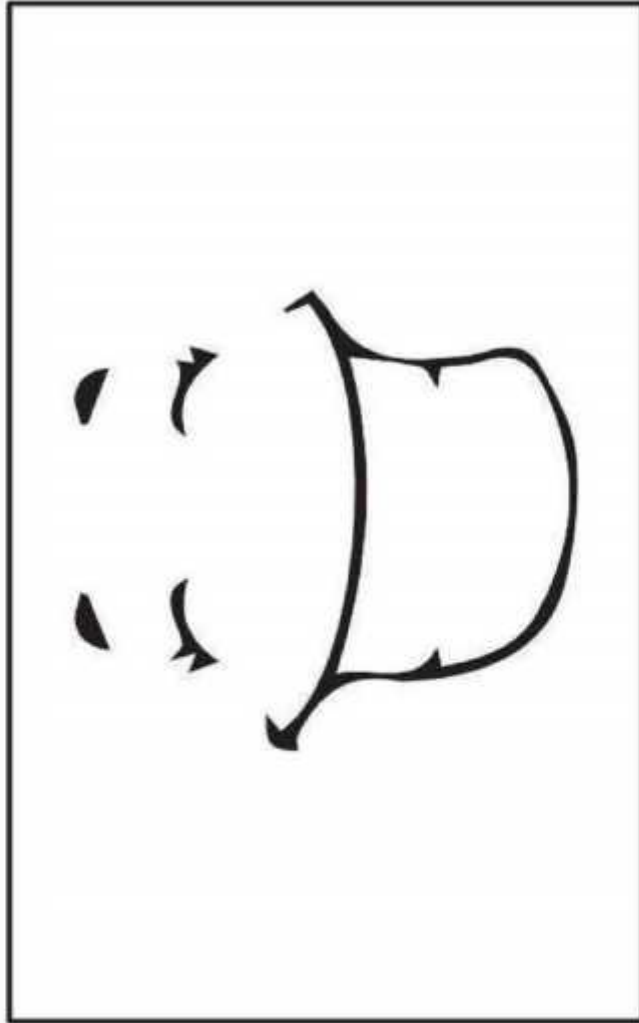

Número 7



Esparce plastilina por los puntos del número 7 y pinta los martillos.

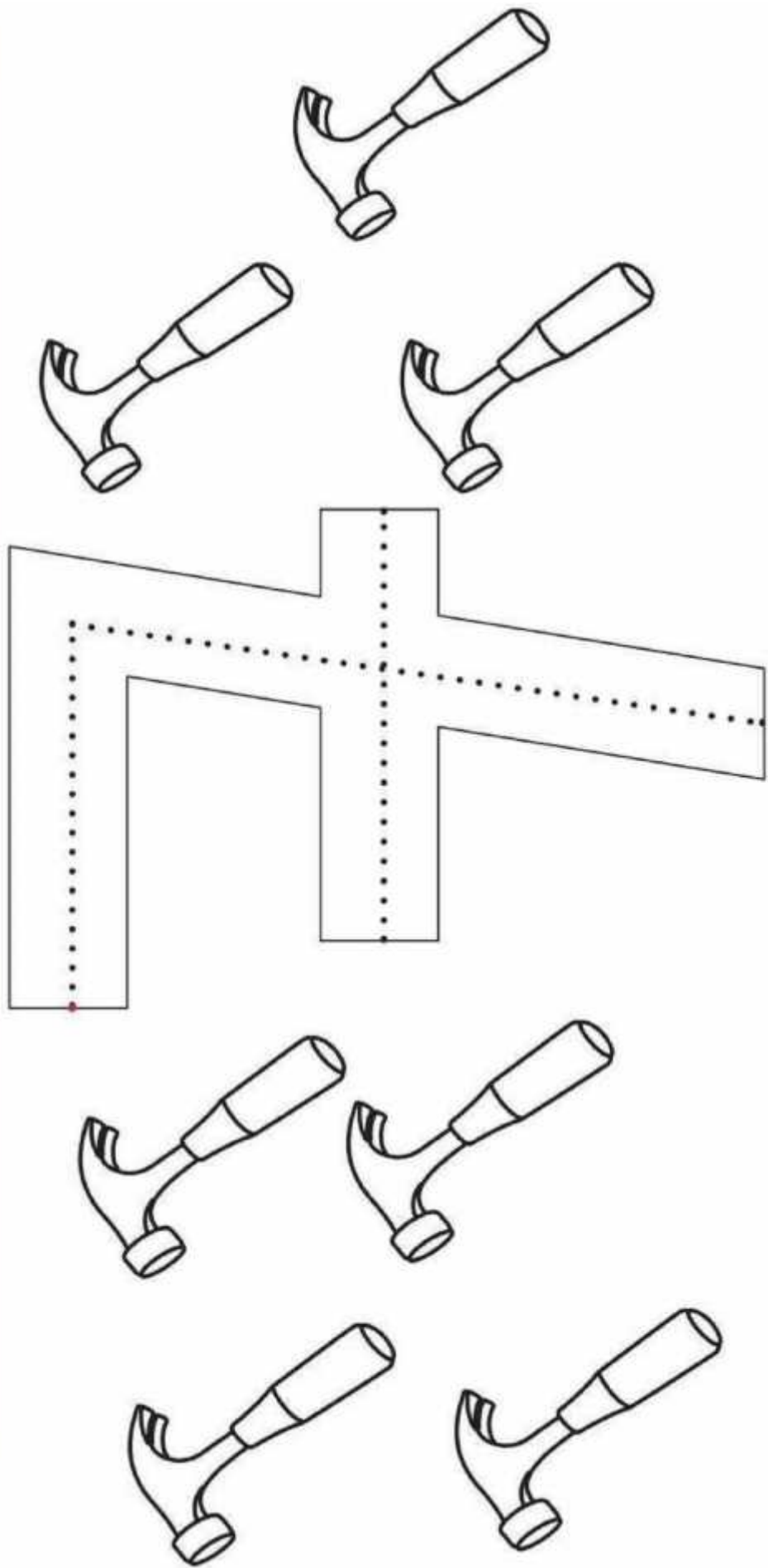

Colorea y repasa por los puntos.

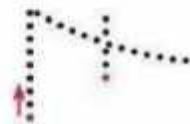
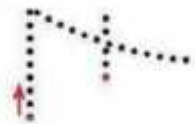
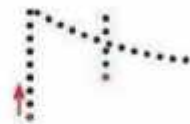
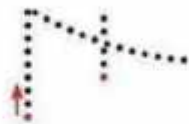
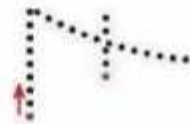
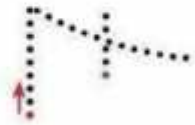
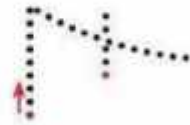
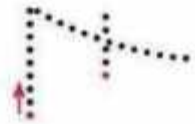
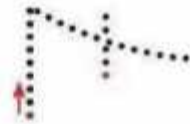
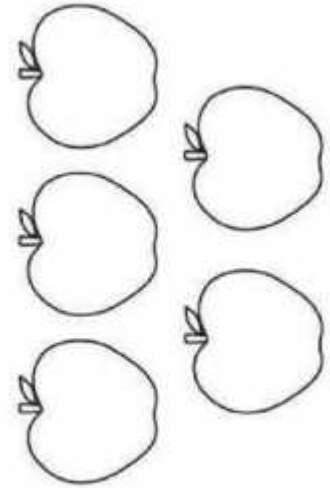
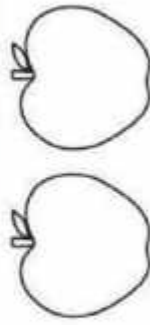

REPASO DE NÚMEROS DEL 1 AL 5



Colorea las prendas de invierno según el número.

2

1

3

5

4

Los números

Instrucciones: traza con un color siguiendo la dirección y cuenta los objetos

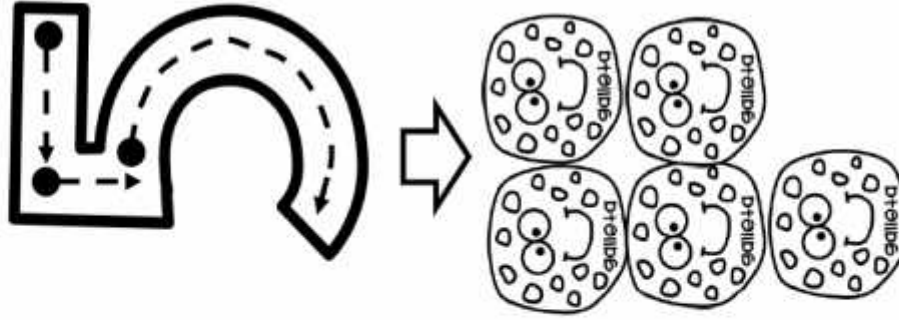
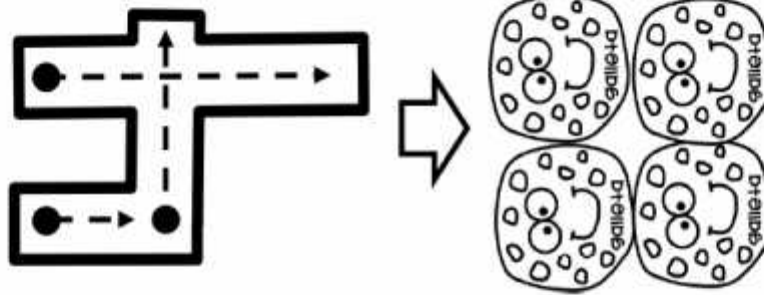
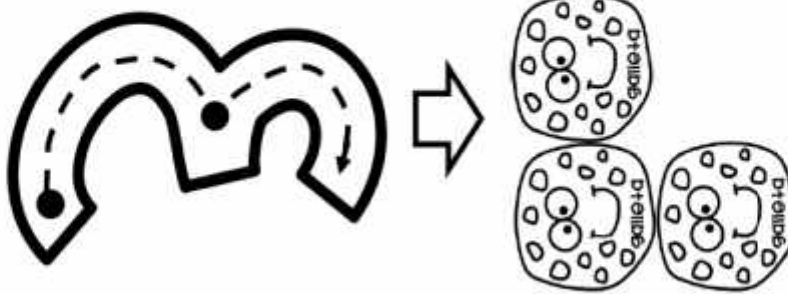
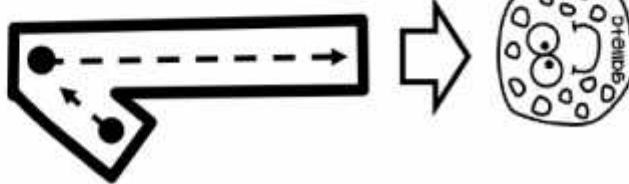

Relación numeral = Cantidad

Cuenta los globos que tengan los ositos y únelos con el número que le corresponda.

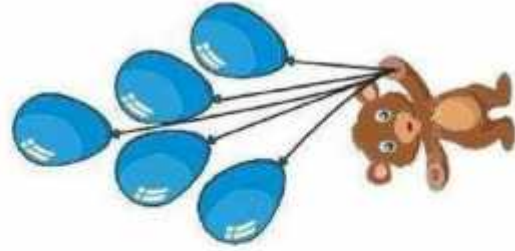
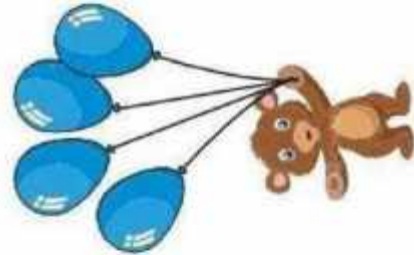
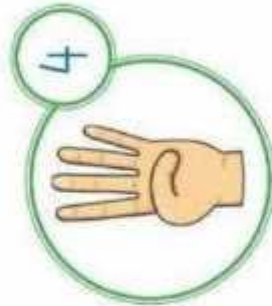
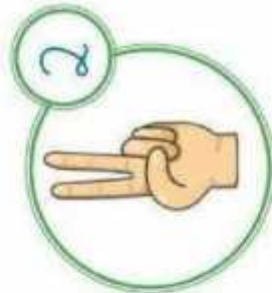
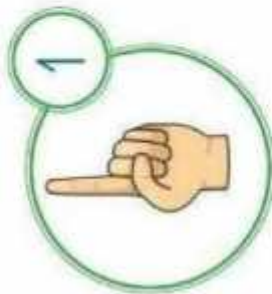

Colorea cada número contando.



1

2

3

4

5

Número 8

Pinta y embolilla papel por las líneas.

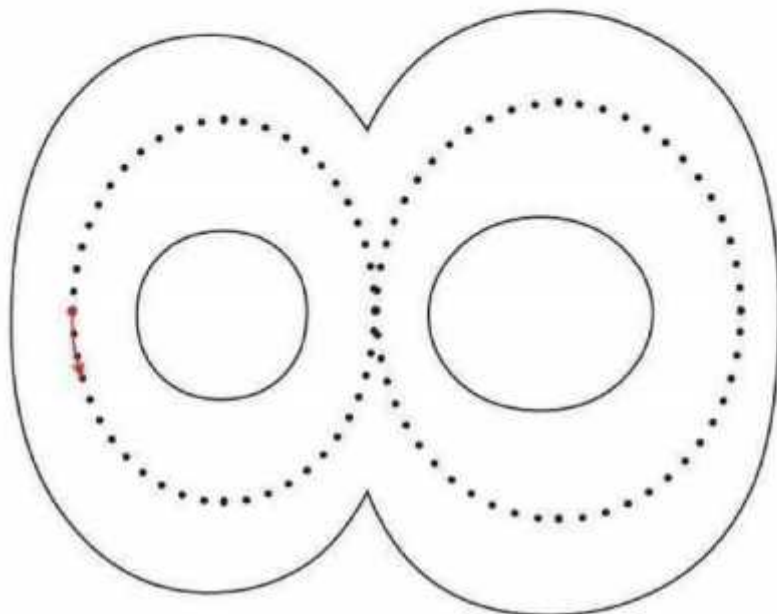
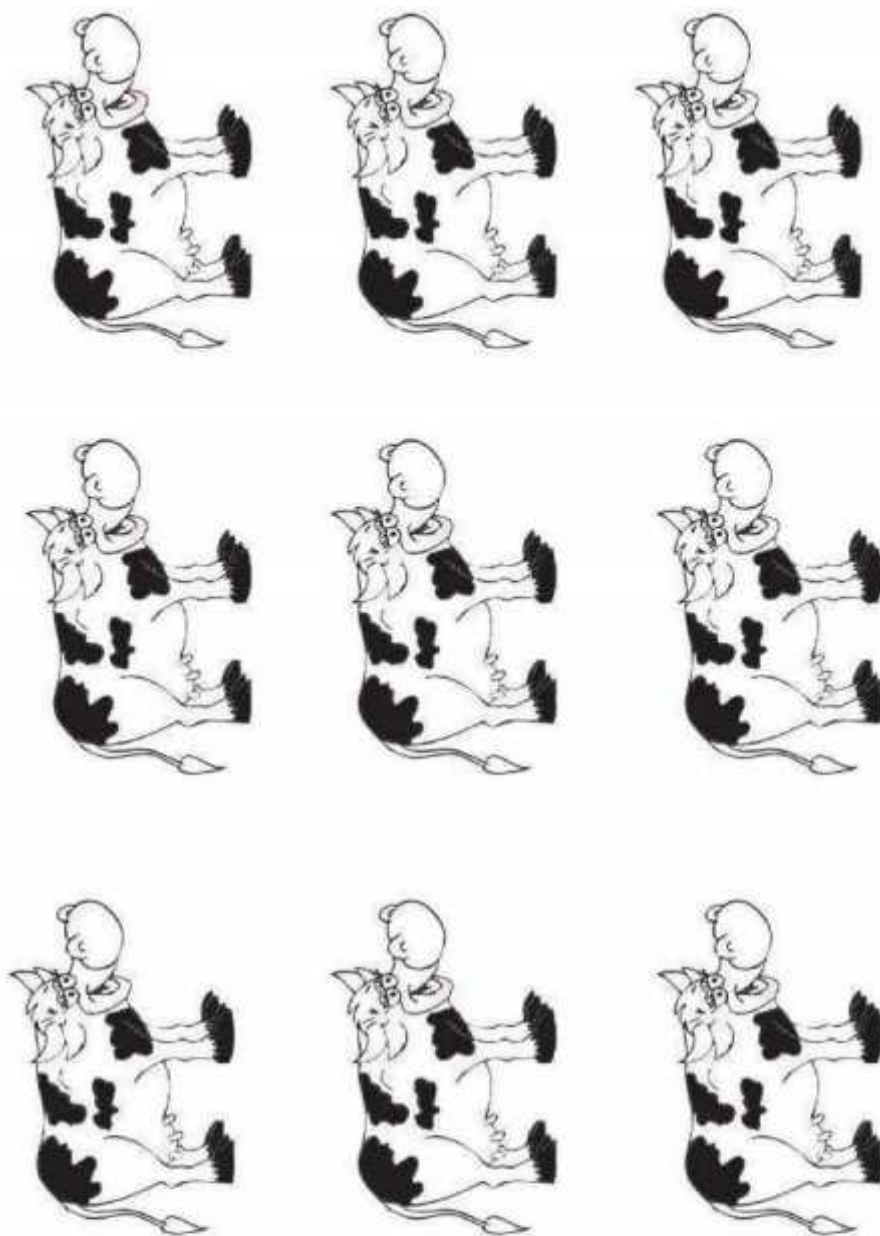



Pinta los globos y repasa por los puntos.

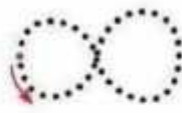
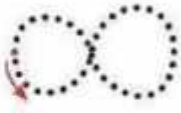
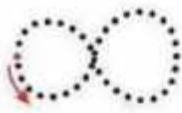
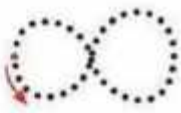
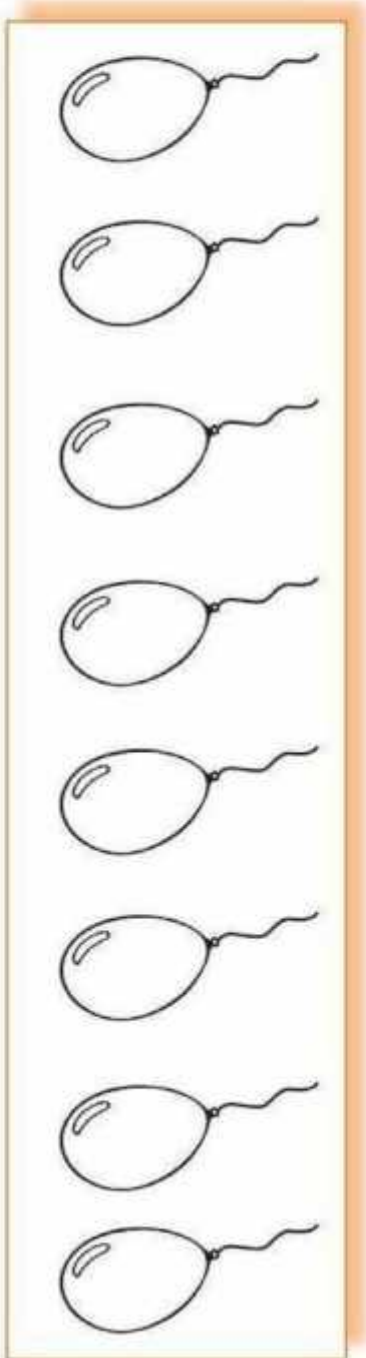

Secuencia de colores



Dibuja y sigue la secuencia según el color.

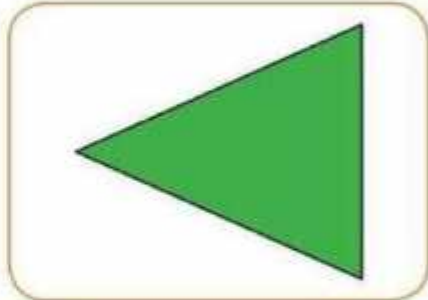
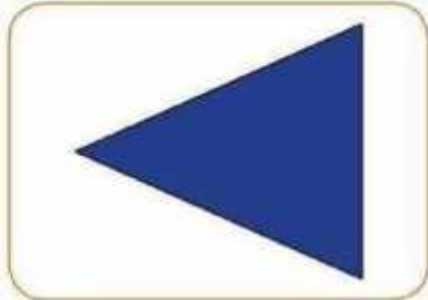
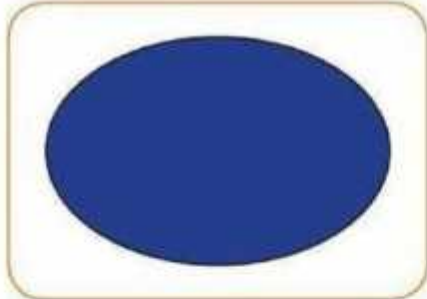
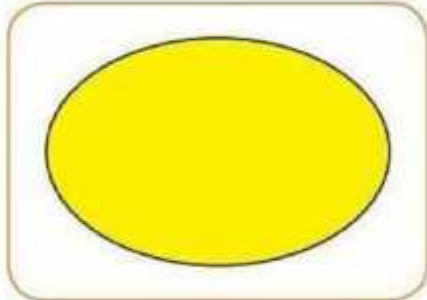
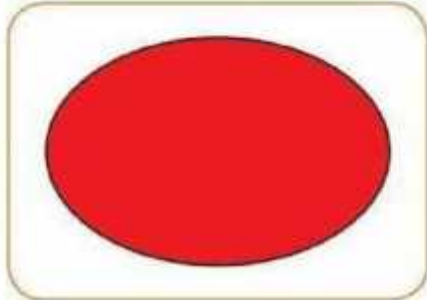



Pinta siguiendo la secuencia.

The image shows a sequence of circles for a coloring activity. The sequence is as follows: a blue circle, a yellow circle, a green circle, and two white circles. After a gap, there is another blue circle, a yellow circle, a green circle, and two white circles. Following another gap, there are three white circles, and finally two more white circles. A teacher character is positioned at the bottom left of the frame, pointing towards the sequence.

Igual - Diferente

Colorea los peces iguales al modelo.

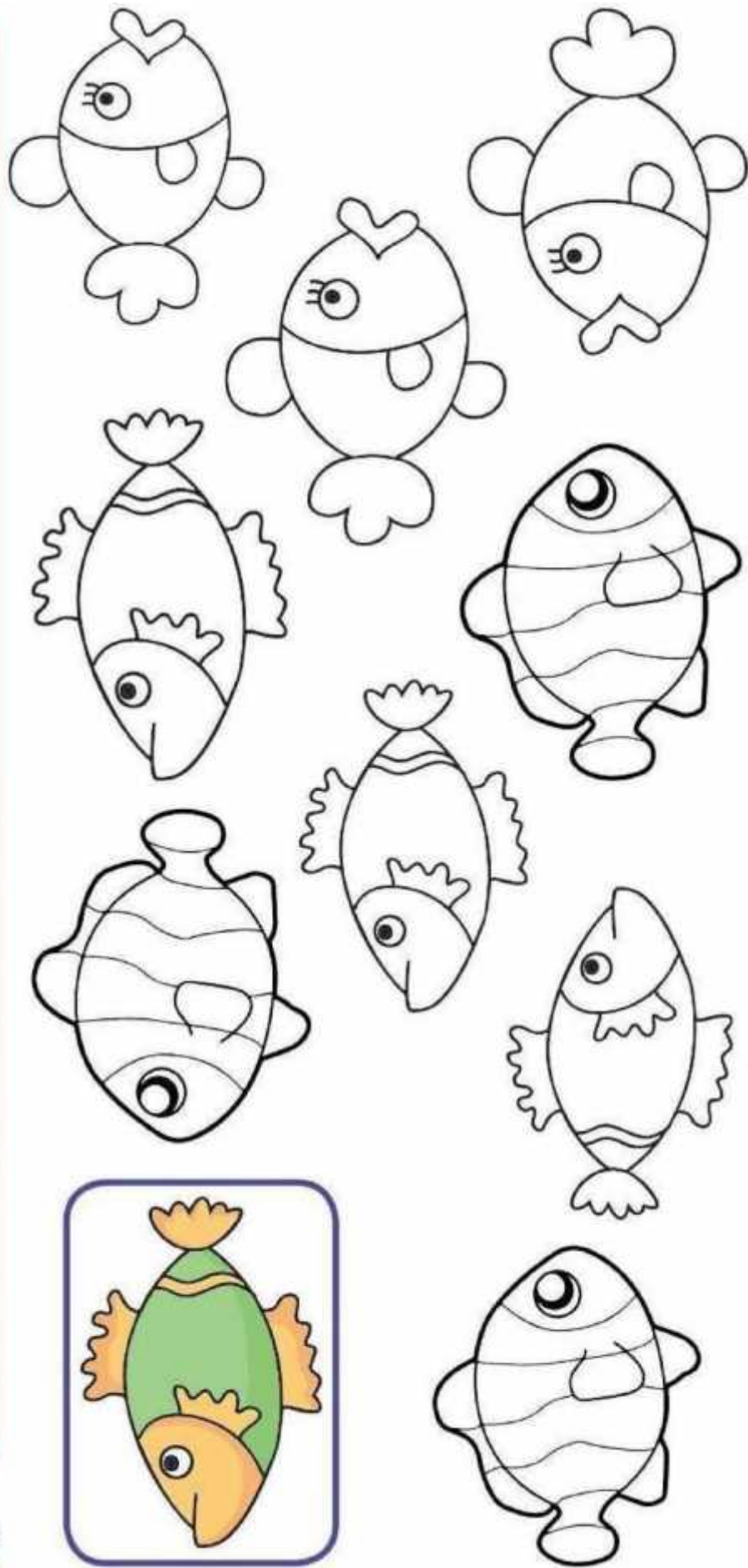
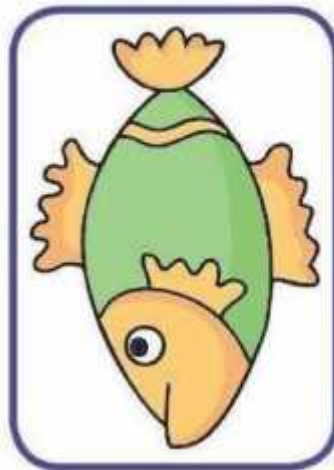

Rodea las figuras iguales al modelo.

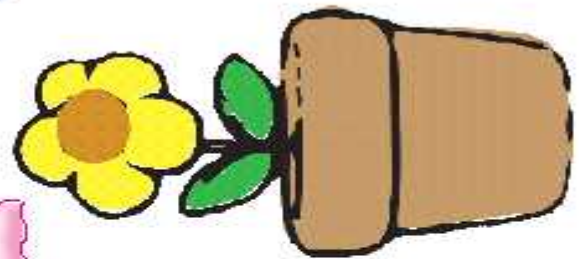
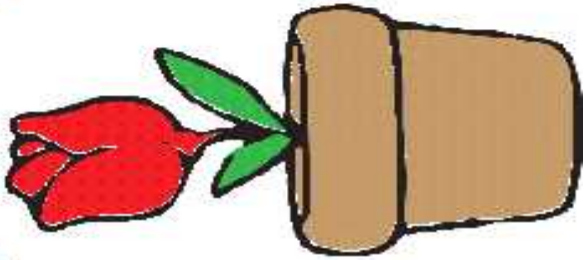
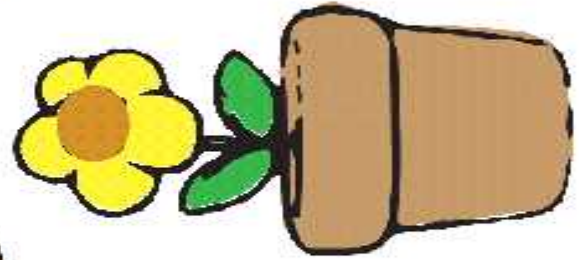
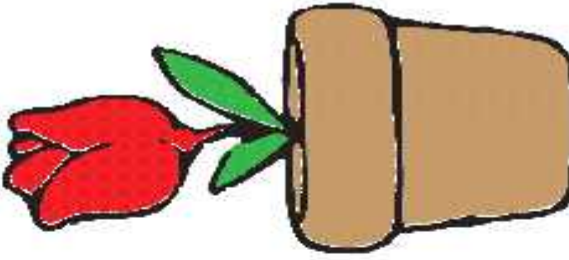
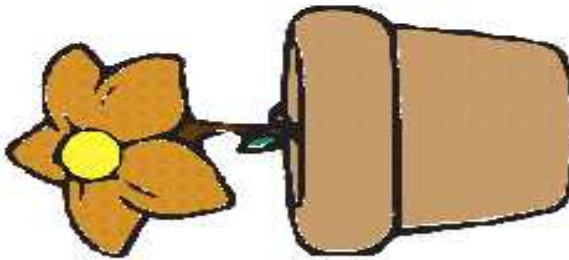
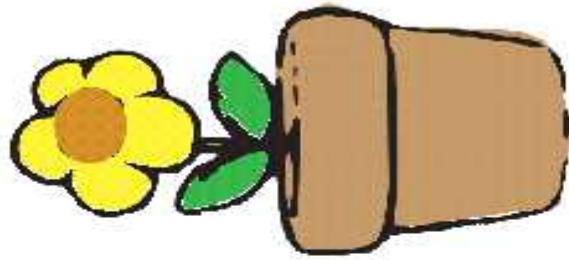
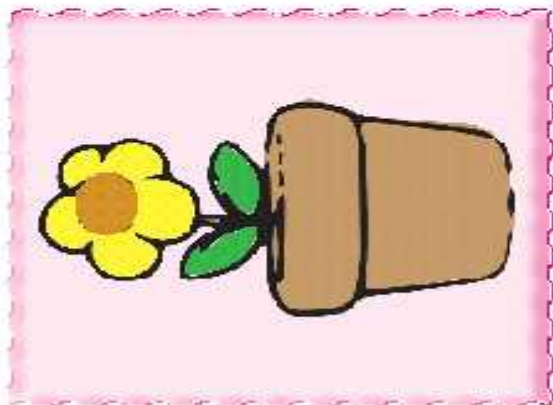

COLOR ANARANJADO

Mescla tempera amarilla y roja y forma el color anaranjado. Luego pinta.

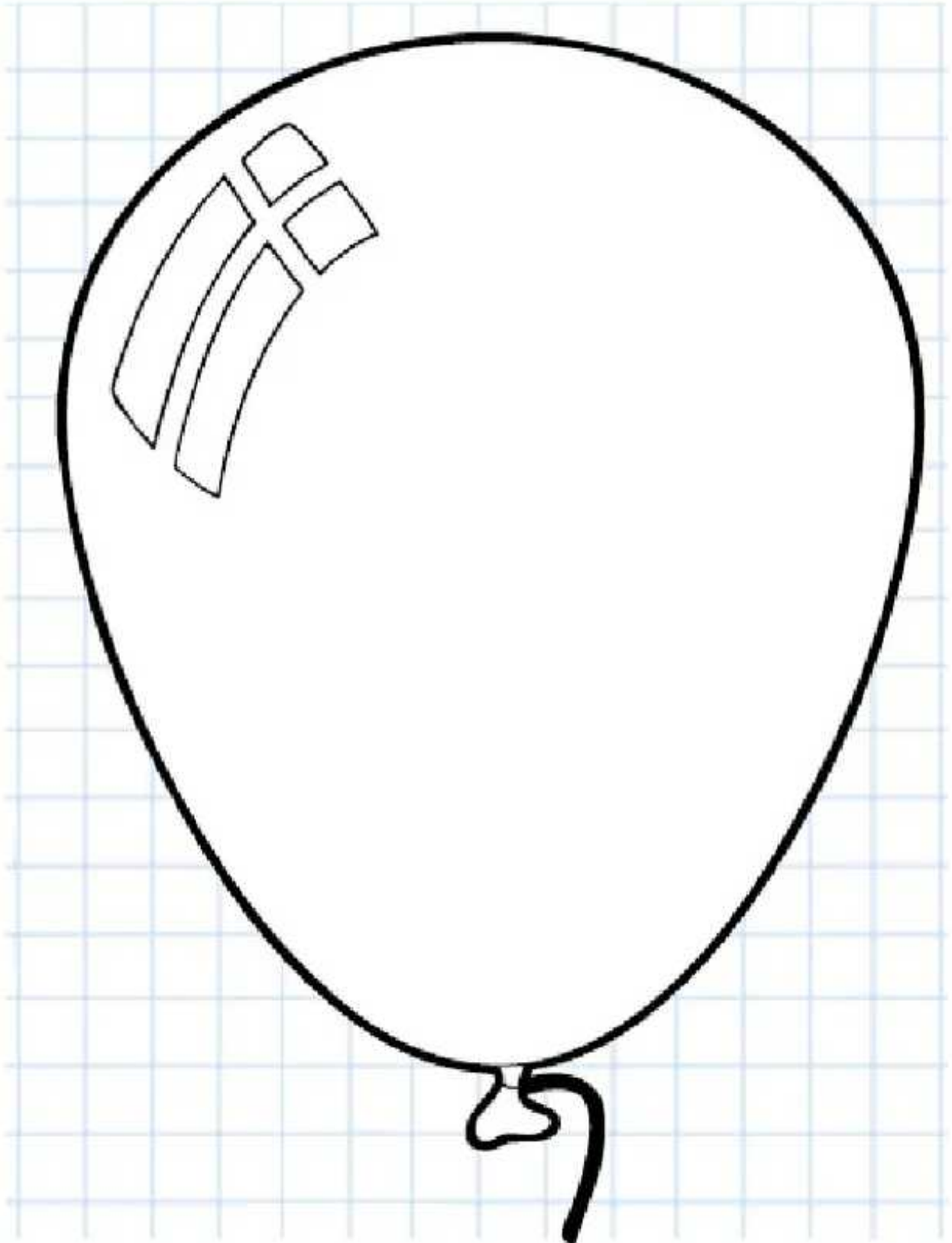

ANARANJADO



Pinta la zanahoria con pintura color anaranjado.

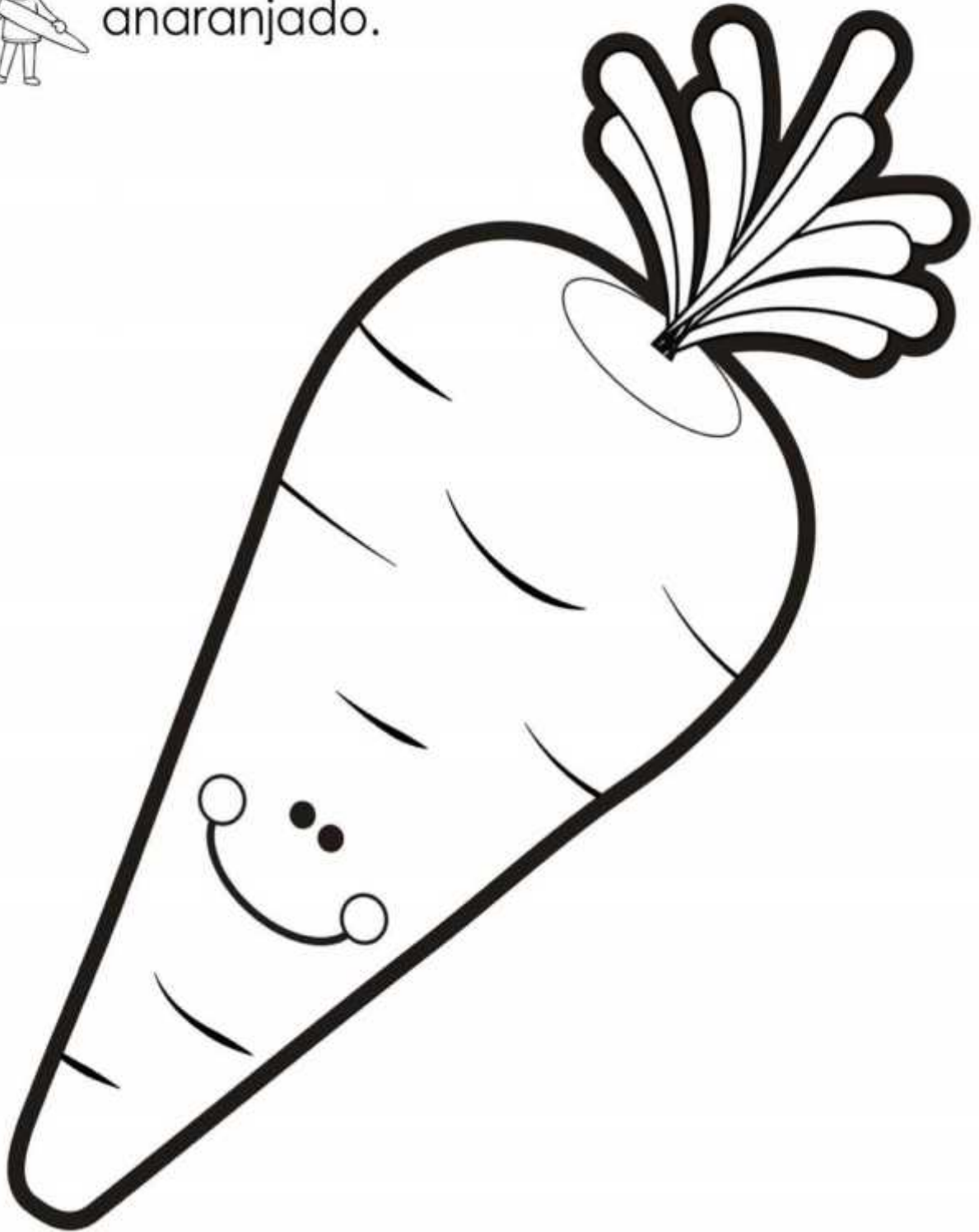

Figuras simples



Repasa los cuadrados, círculos y triángulos. Colorea los dibujos de caras.

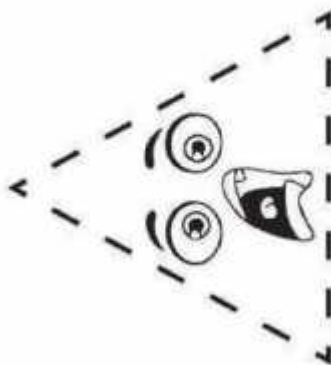
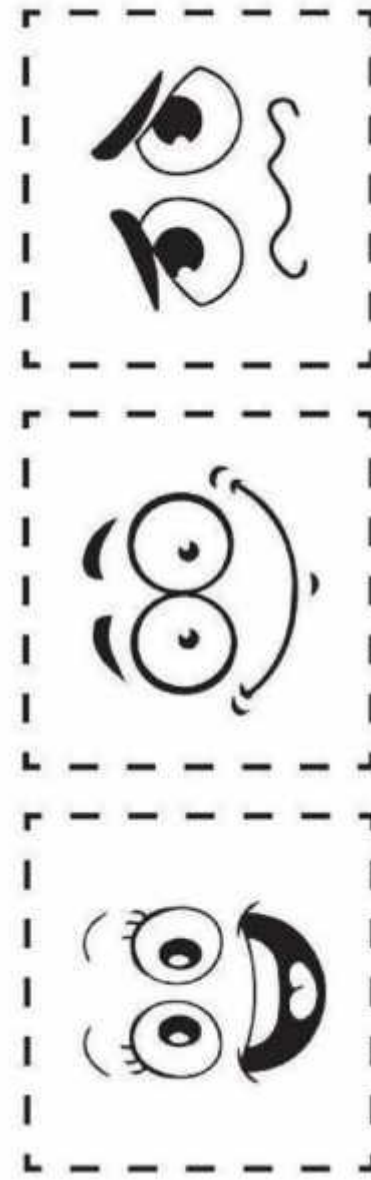
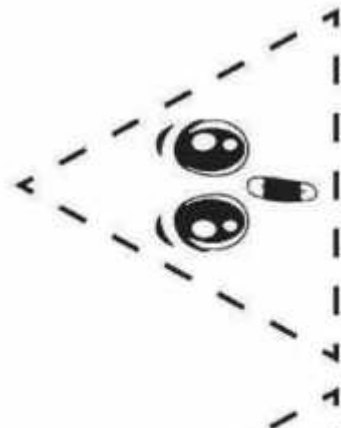
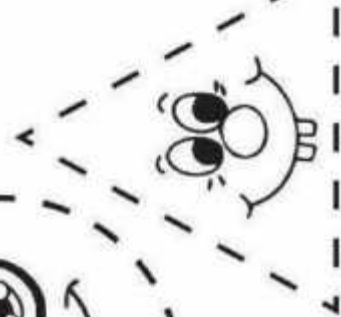

Absurdos



Encierra en un círculo los absurdos que encuentres en la imagen.





Observa y marca (X) los absurdos que encuentren en las imágenes.

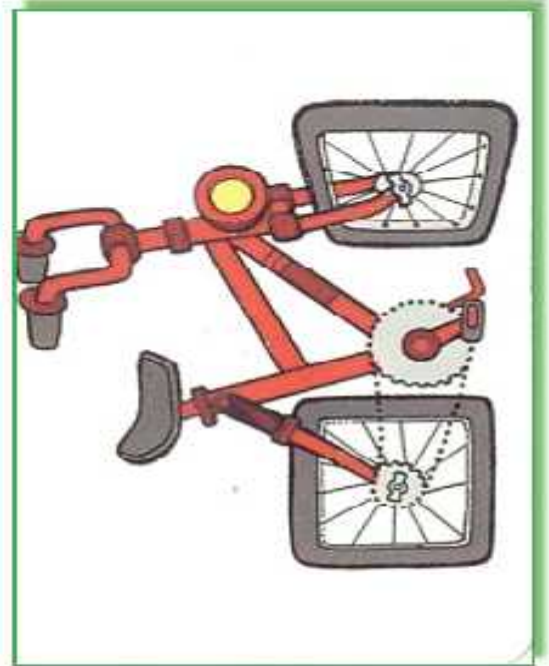

Número 9



Deja tus huellitas con tempera en el número 9 y colorea las imágenes.

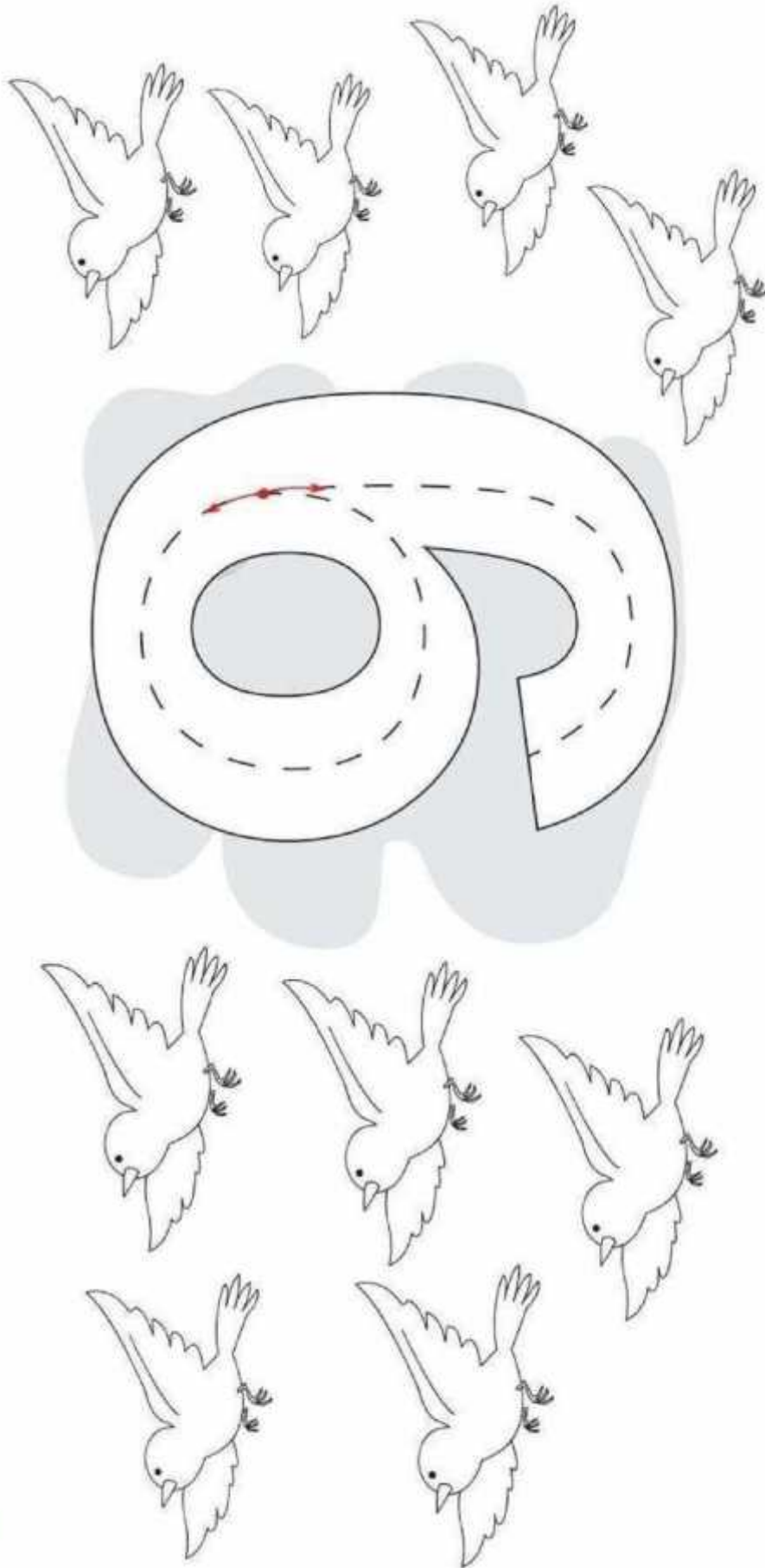

Número 9

Repasa y colorea. Colorear nueve jarras.



A 5x3 grid of dotted number 9s for tracing. Each number 9 has a red dot at the top of the vertical line and a red arrow pointing to the right, indicating the starting point and direction of the stroke. Below the grid are nine watering cans arranged in a 3x3 grid, each with a flower and a leaf on its side, intended for coloring.

EL OVALO

Pega bolitas de papel alrededor del ovalo

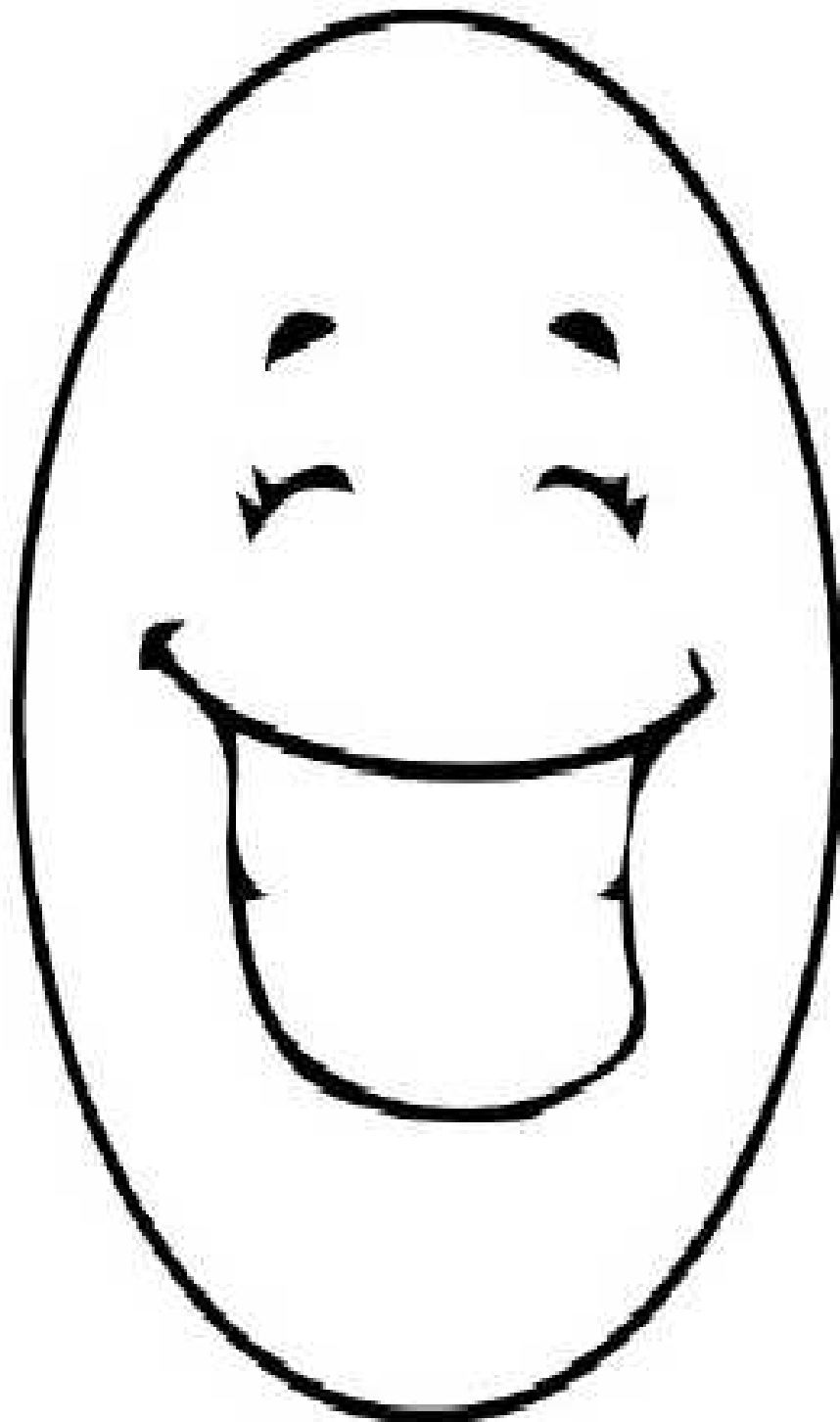

Repasa por las líneas punteadas con plumón grueso.

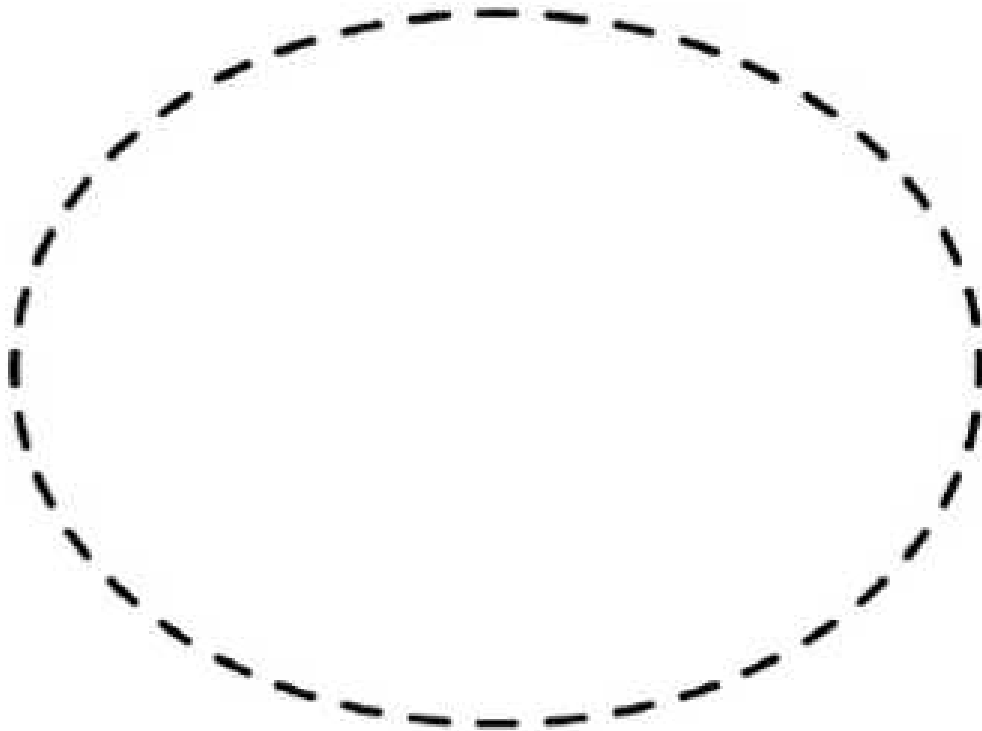
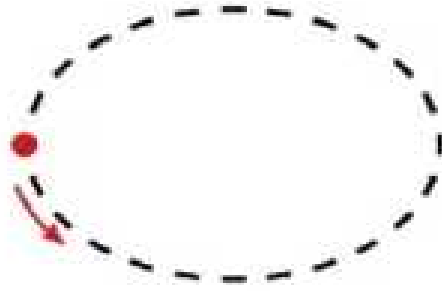
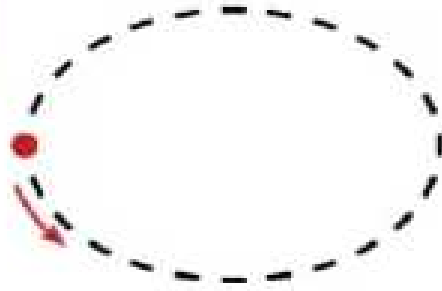
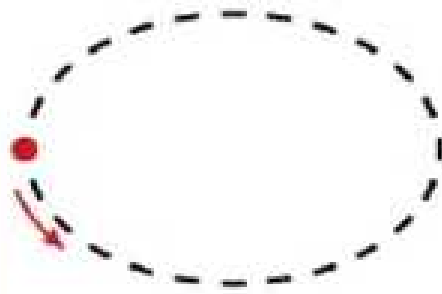

Número 10



Pinta el número 10 cada uno de diferentes colores.

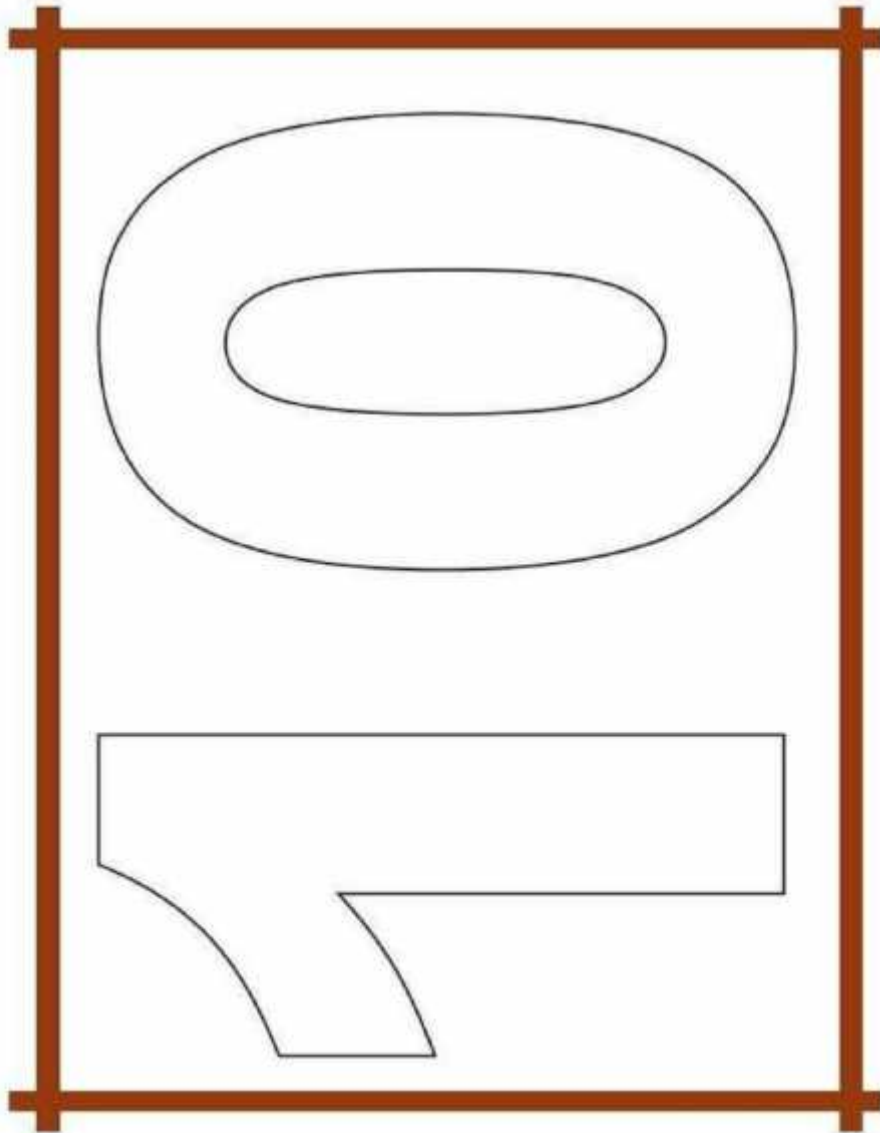

10 10 10

10 10 10

10 10 10

Diez 10



• Repasa el contorno del número 10 y luego colorea los 10 objetos.

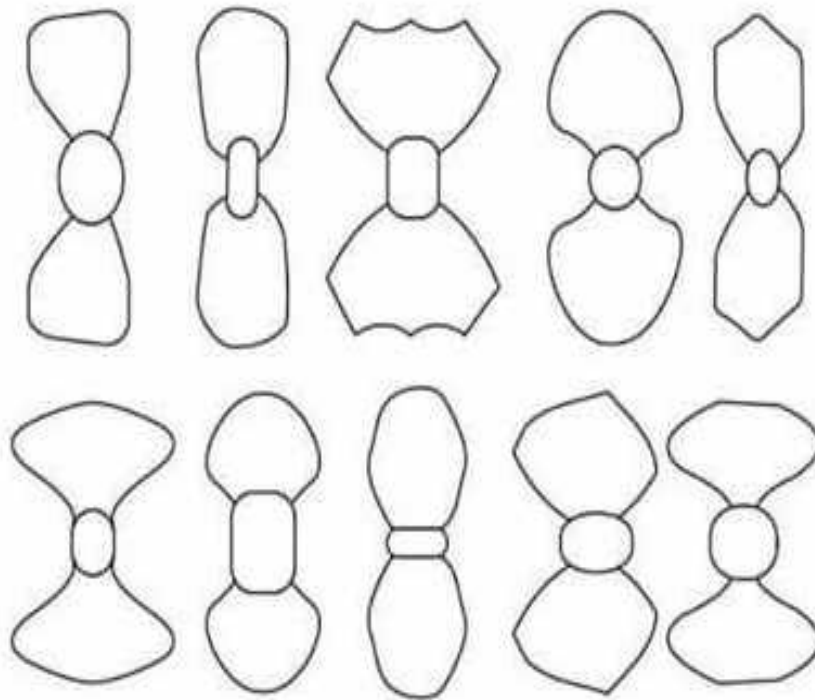
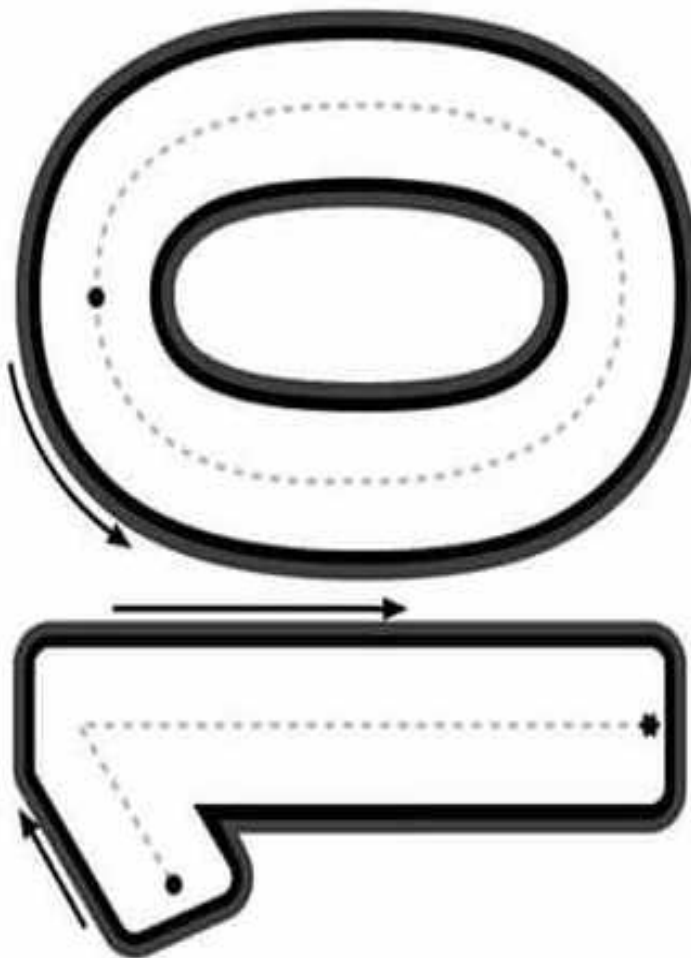

Práctica de los números del 1 al 10



Completa la serie de números y pinta el gusano de colores.



Grande = Mediano = Pequeño



Rasga papel de colores y pega en el payaso mediano.

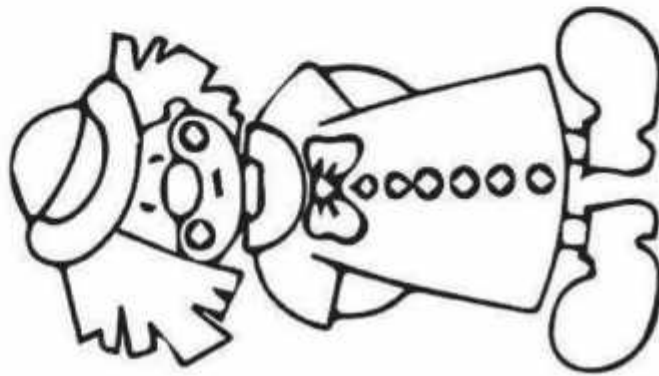
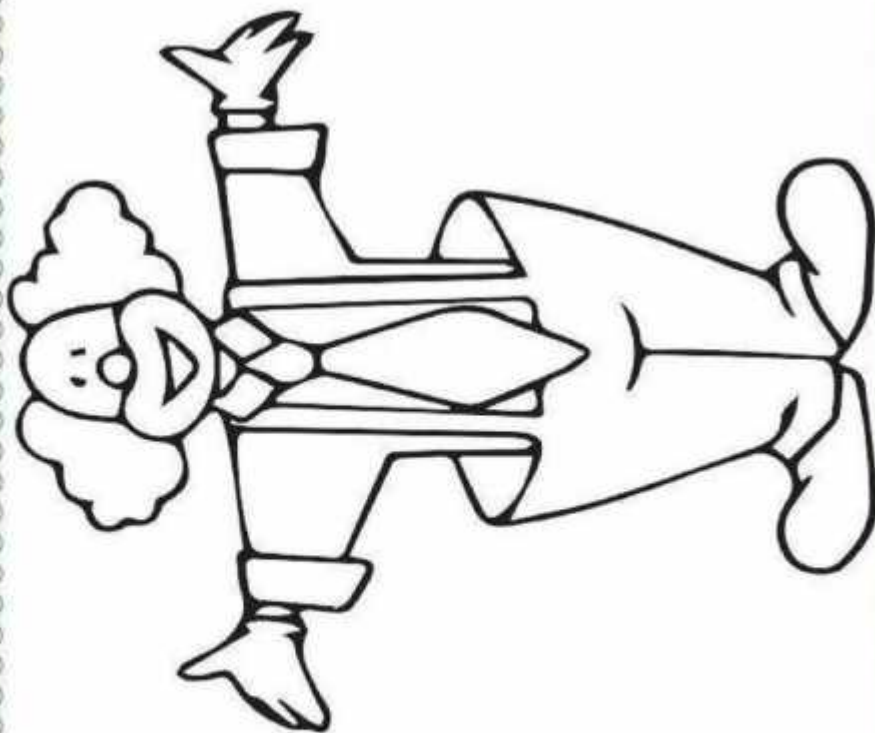



Colorea los lápices grandes y enciérralos con una línea.

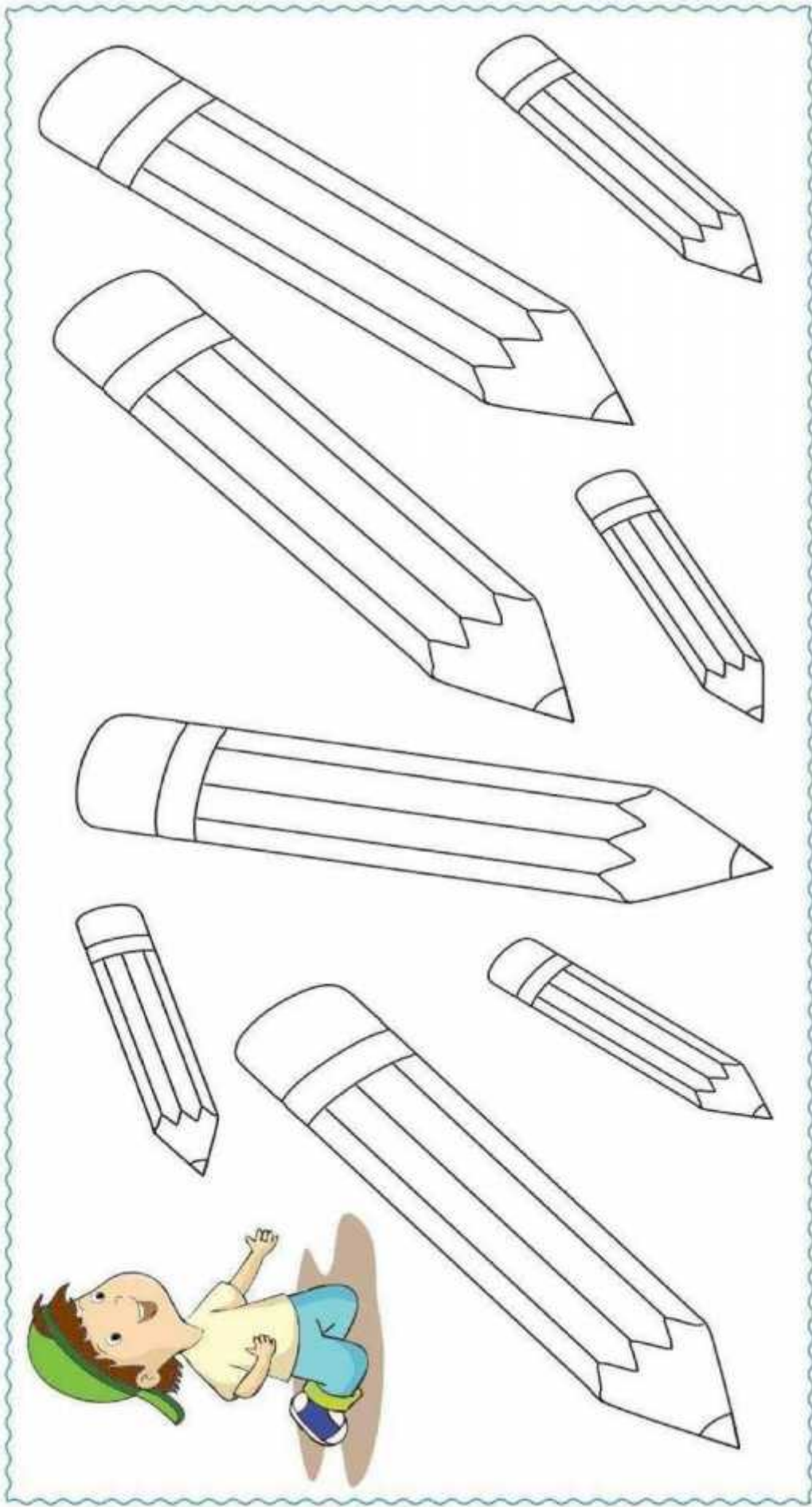

Entero = Mitad



Encierra en un círculo la palta que esta partida. Marca con una (X) la naranja entera.

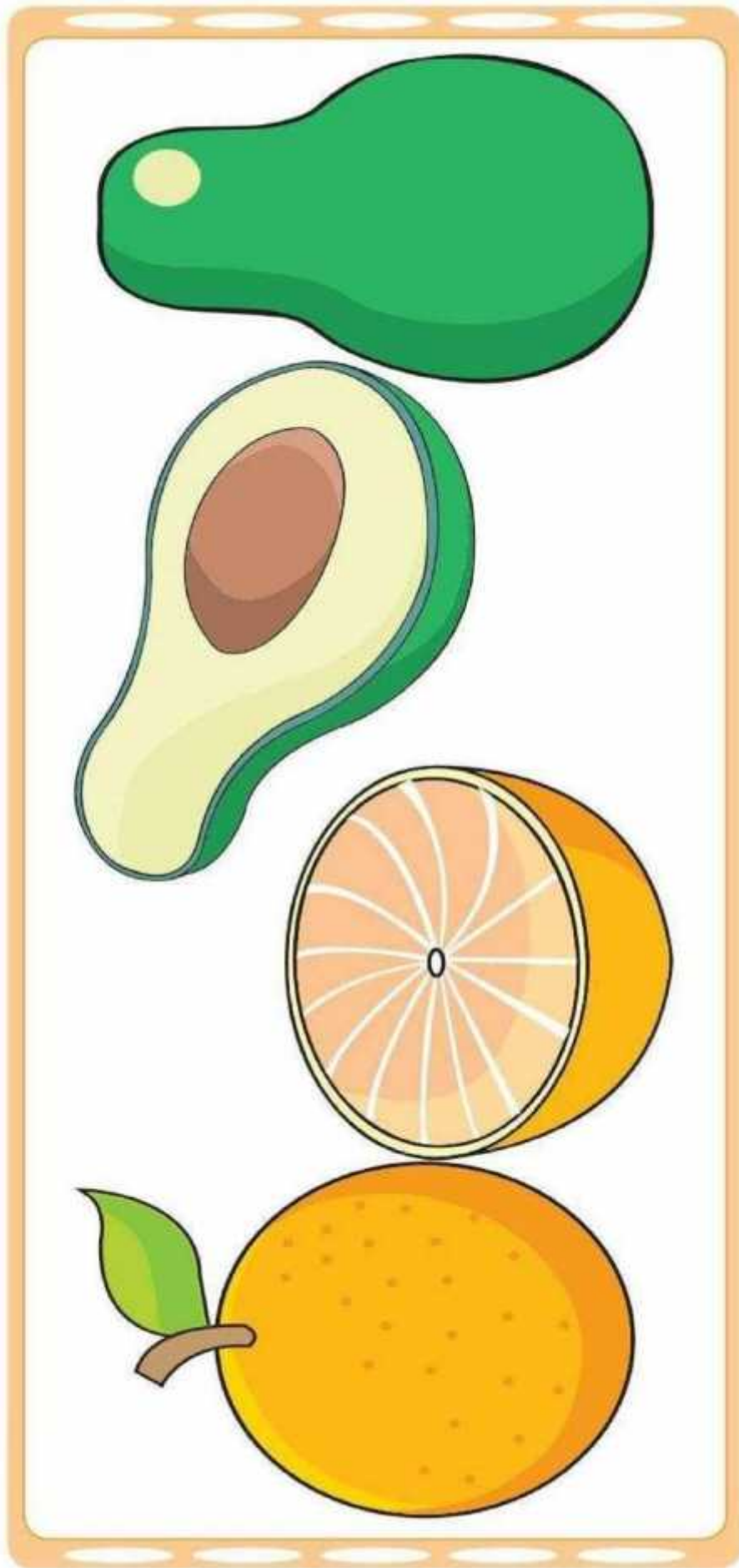

Entero - Partido

Deja tus huellitas de témperas en la sandía entera, y colorea la sandía que esta a la mitad.

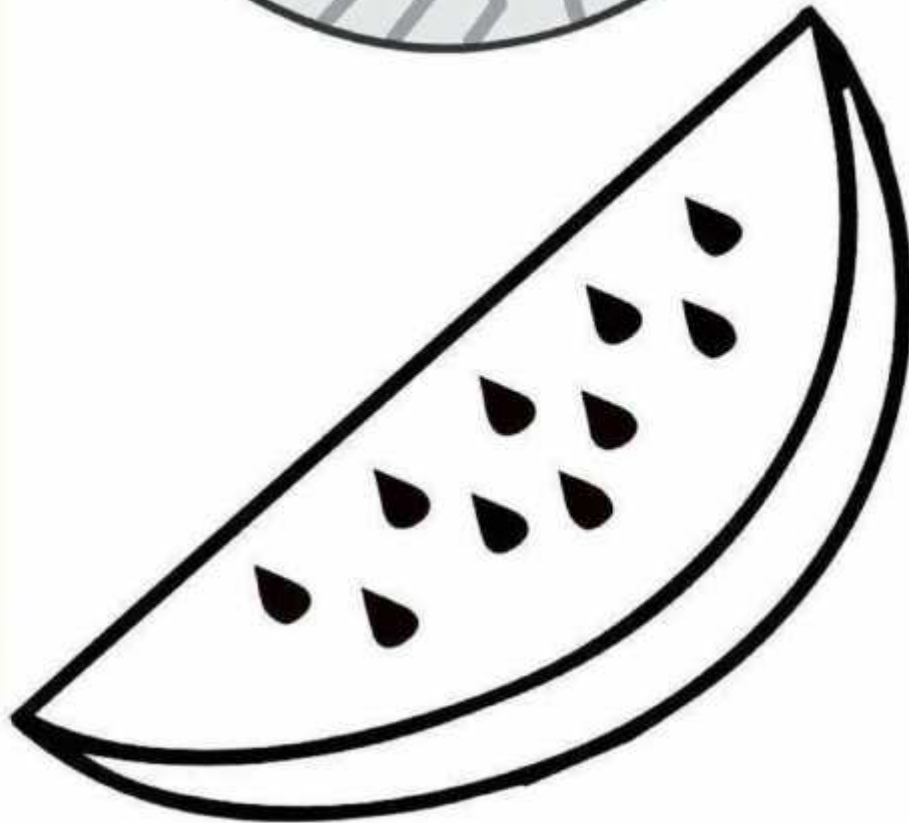
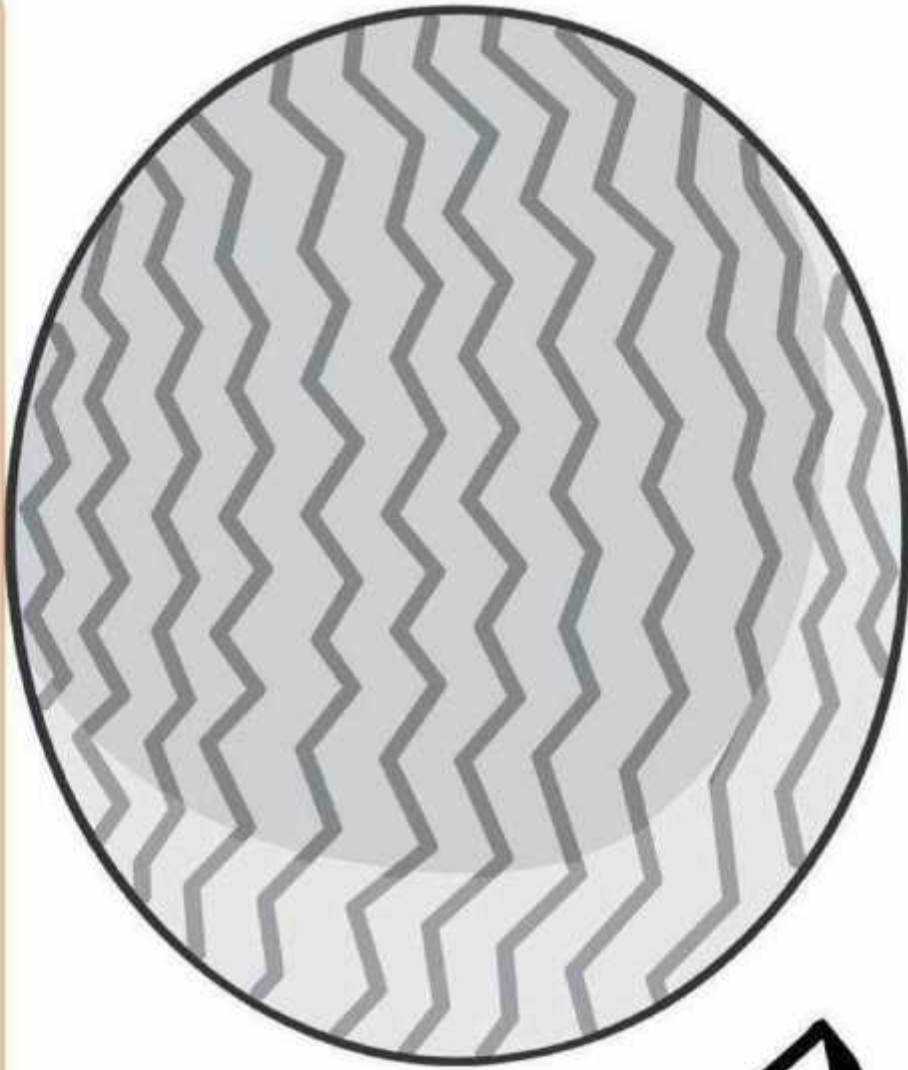

OBJETOS OCULTOS

-Buscamos y coloramos .

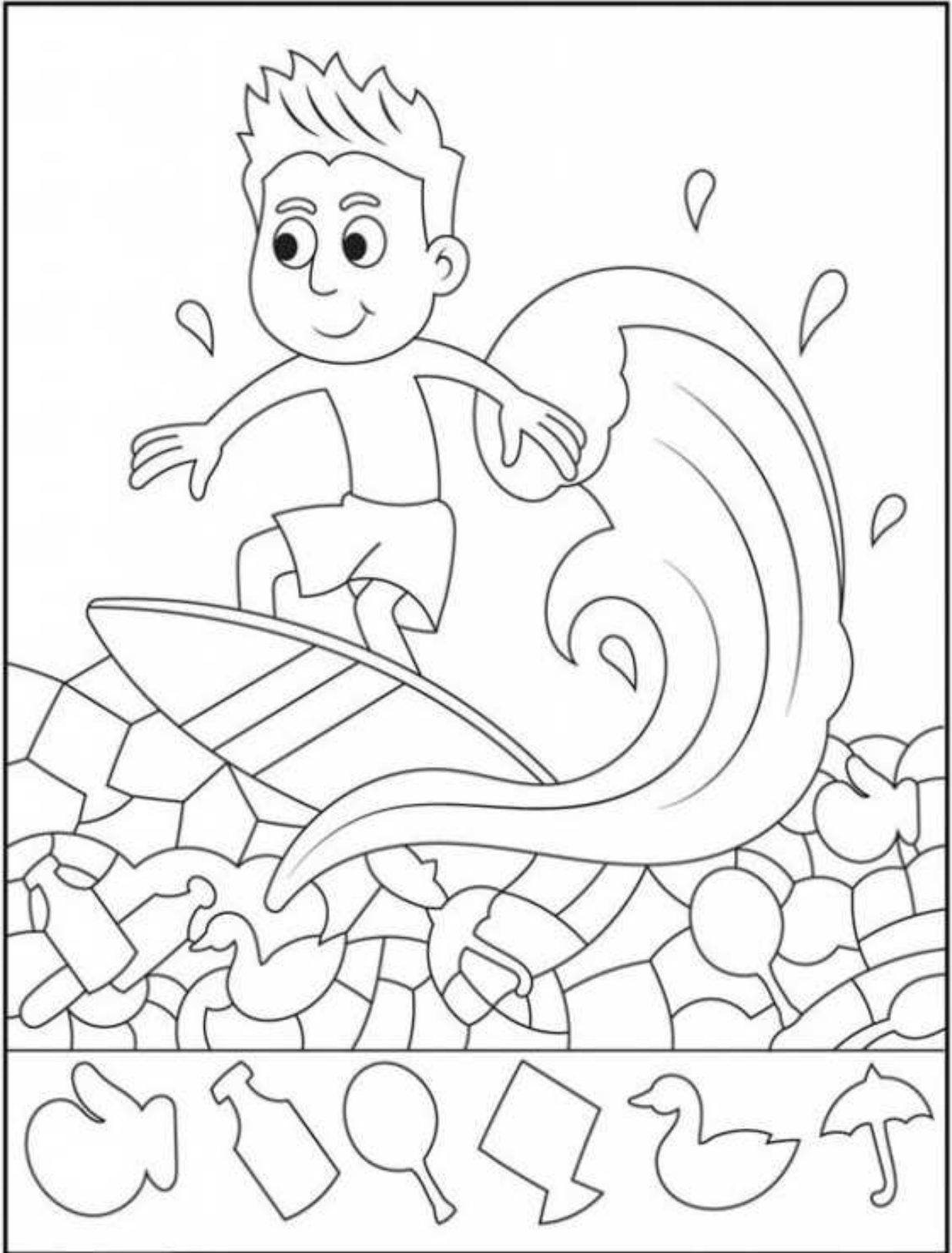

Objetos Ocultos

Colorea el serrucho.

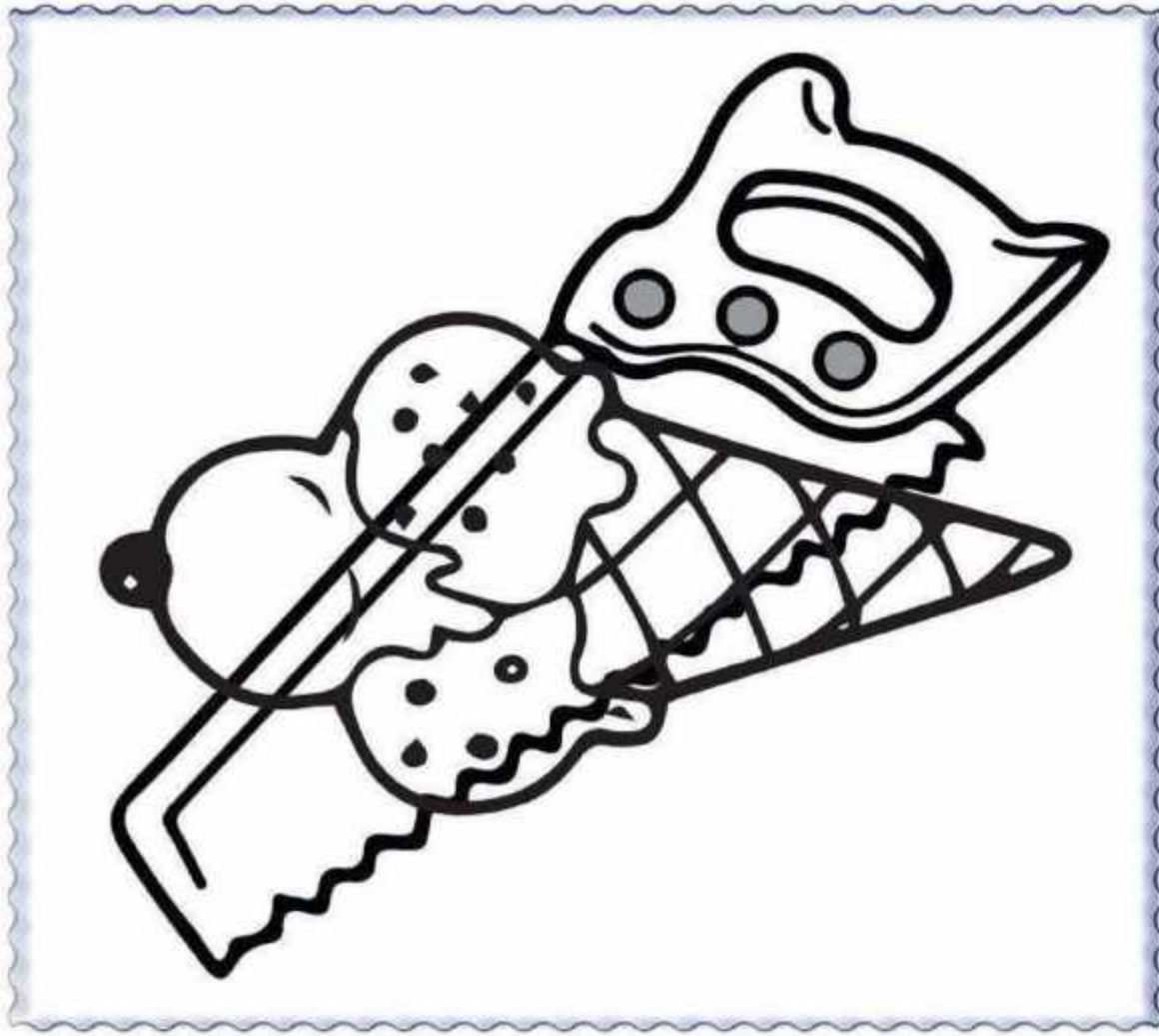

Color blanco



Pega algodón en el conejo.

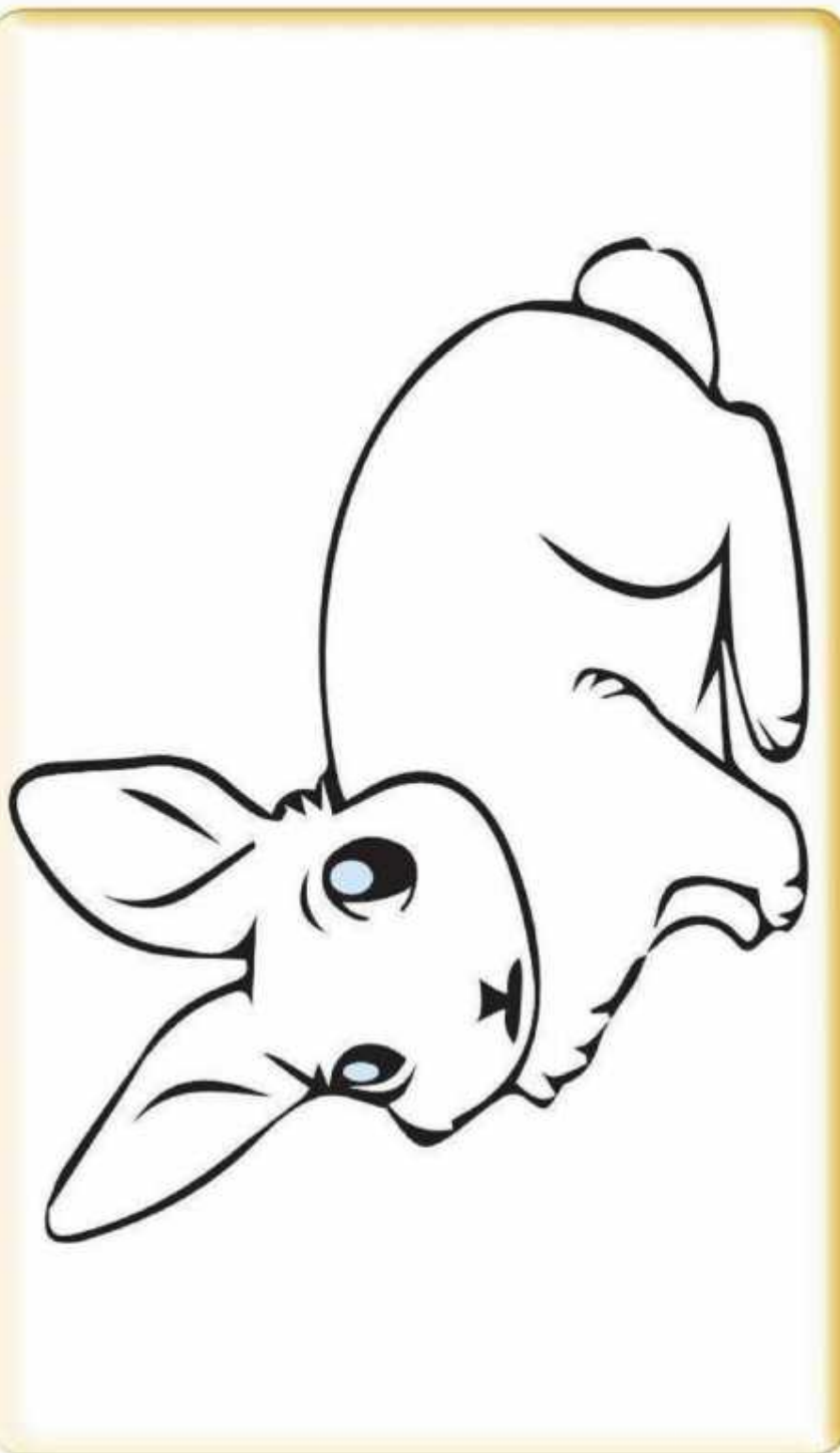

Colorea del color indicado y comenta que otros objetos de este color conoces.

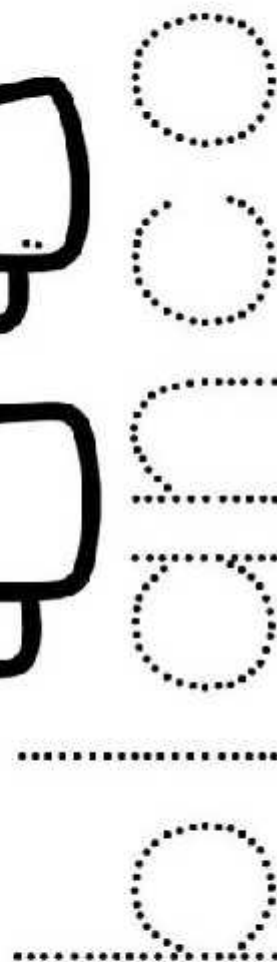
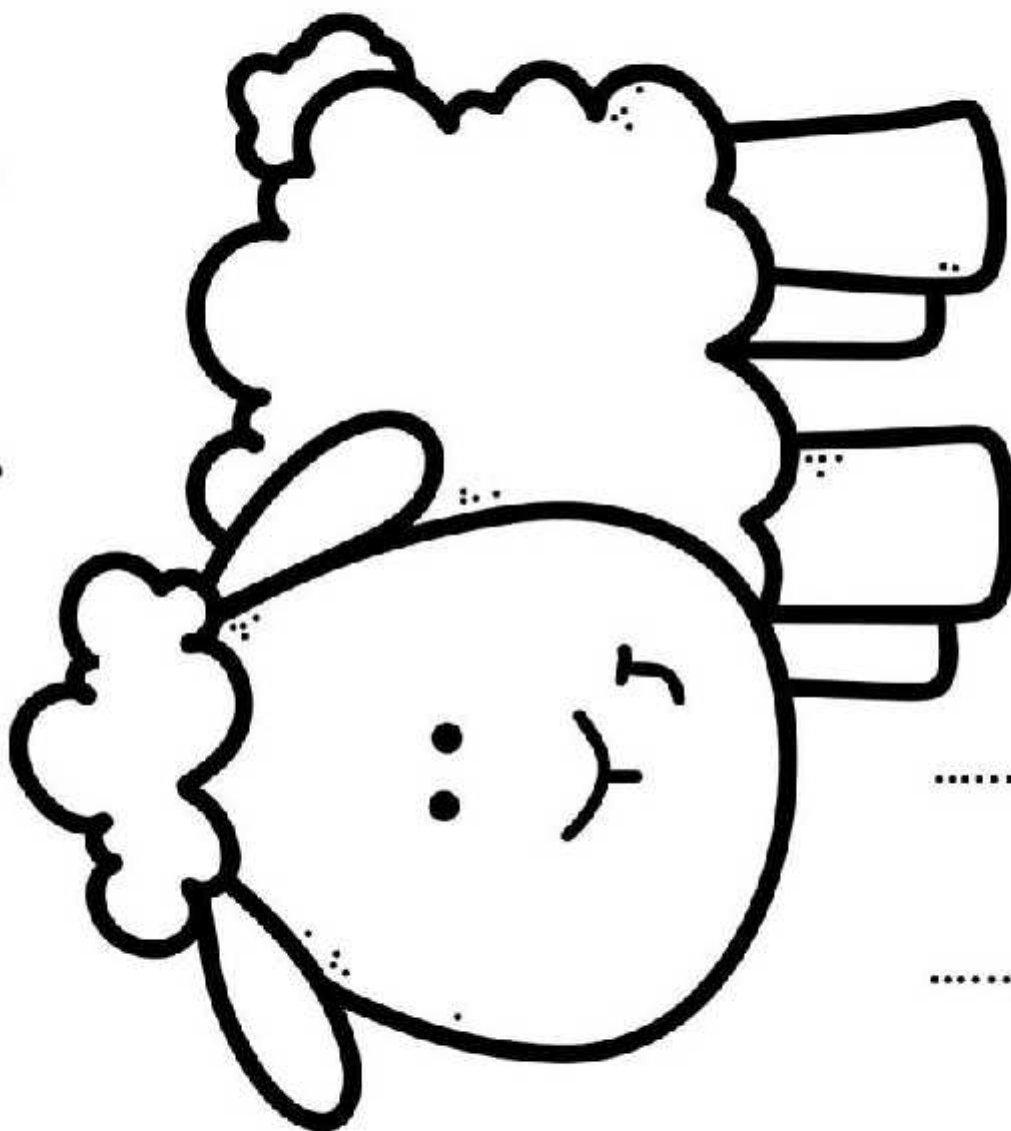

Direccionalidad



Colorea de amarillo los caracoles que van hacia la derecha y de verde los que van hacia la izquierda.



Más = Menos

Colorea donde hay más globos.

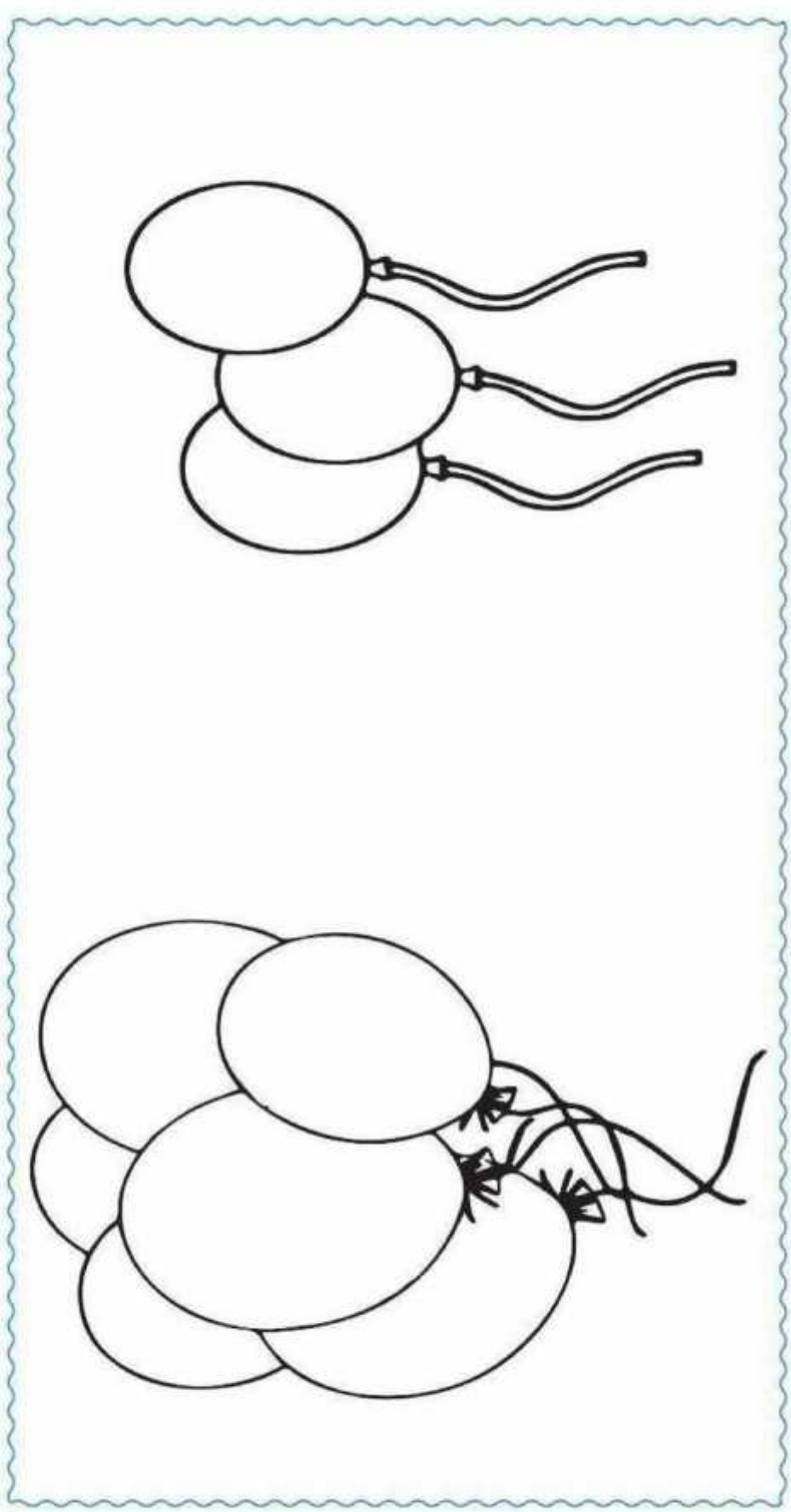



Encierra donde hay más búhos y marca con una (+) donde hay menos búhos.

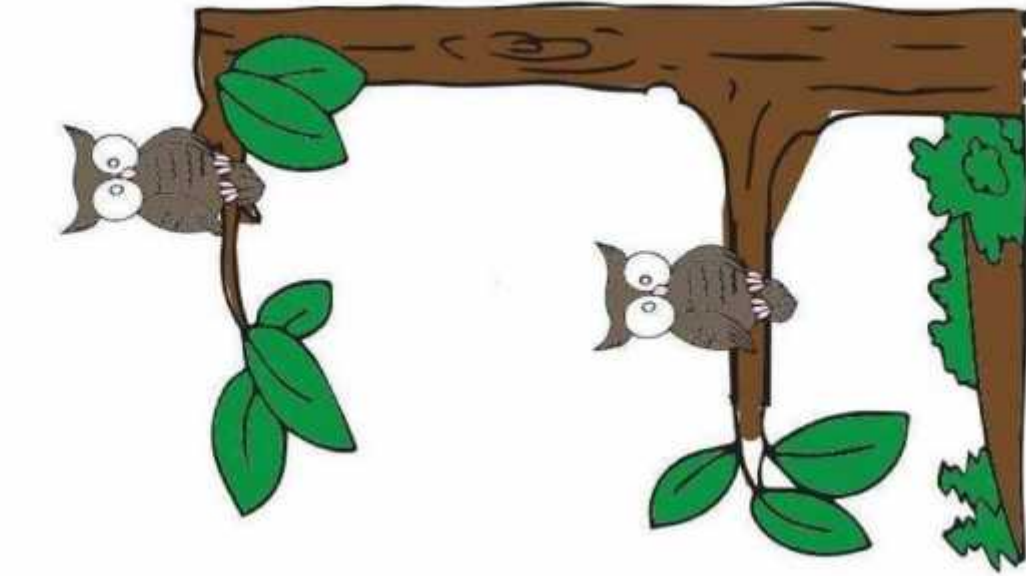
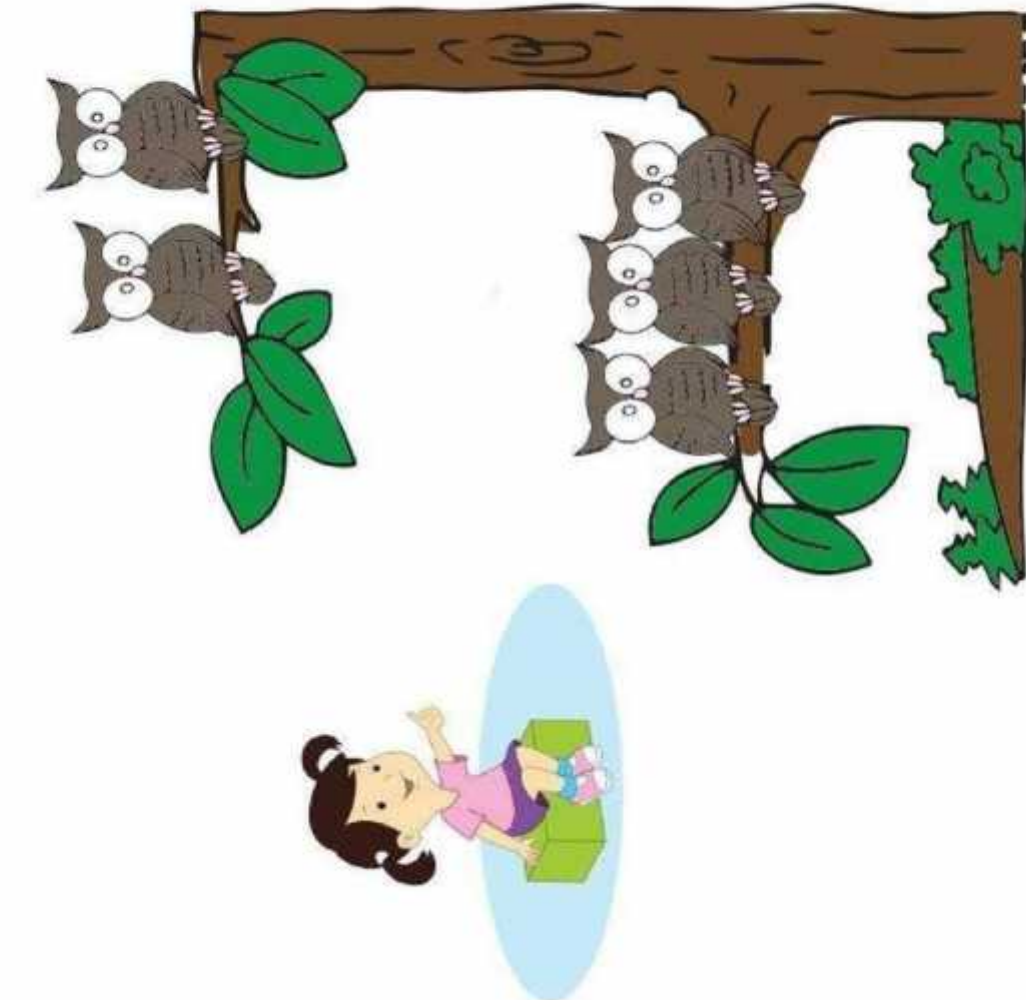

Noción - más o menos



Rodea y pinta el grupo que tiene MÁS.

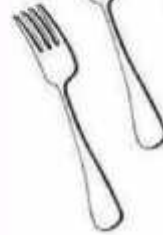
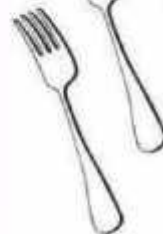
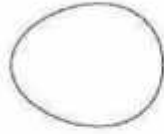
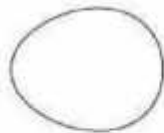
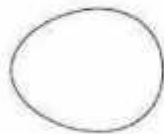
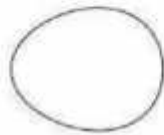

Más - menos



Rodea y pinta el grupo que tiene MÁS.

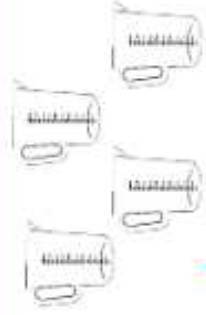
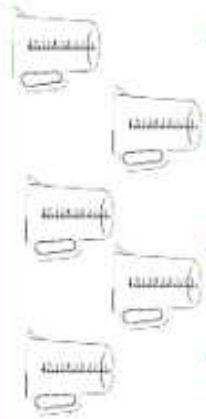
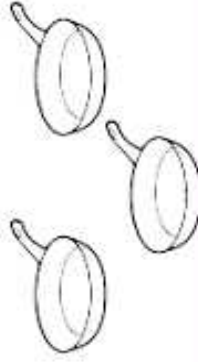
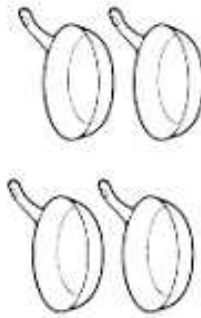
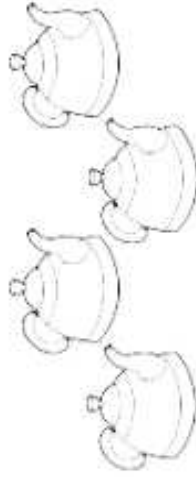
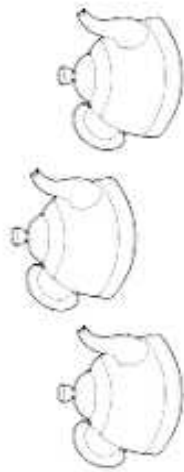
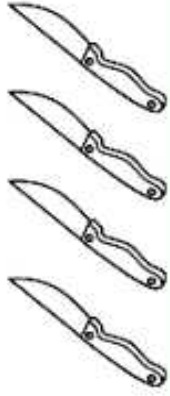
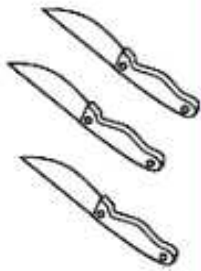

COLOR MORADO

- Delinea y colorea con tu crayola de color morado la berenjena.



Color Morado

Pega bolitas de papel en la uva.

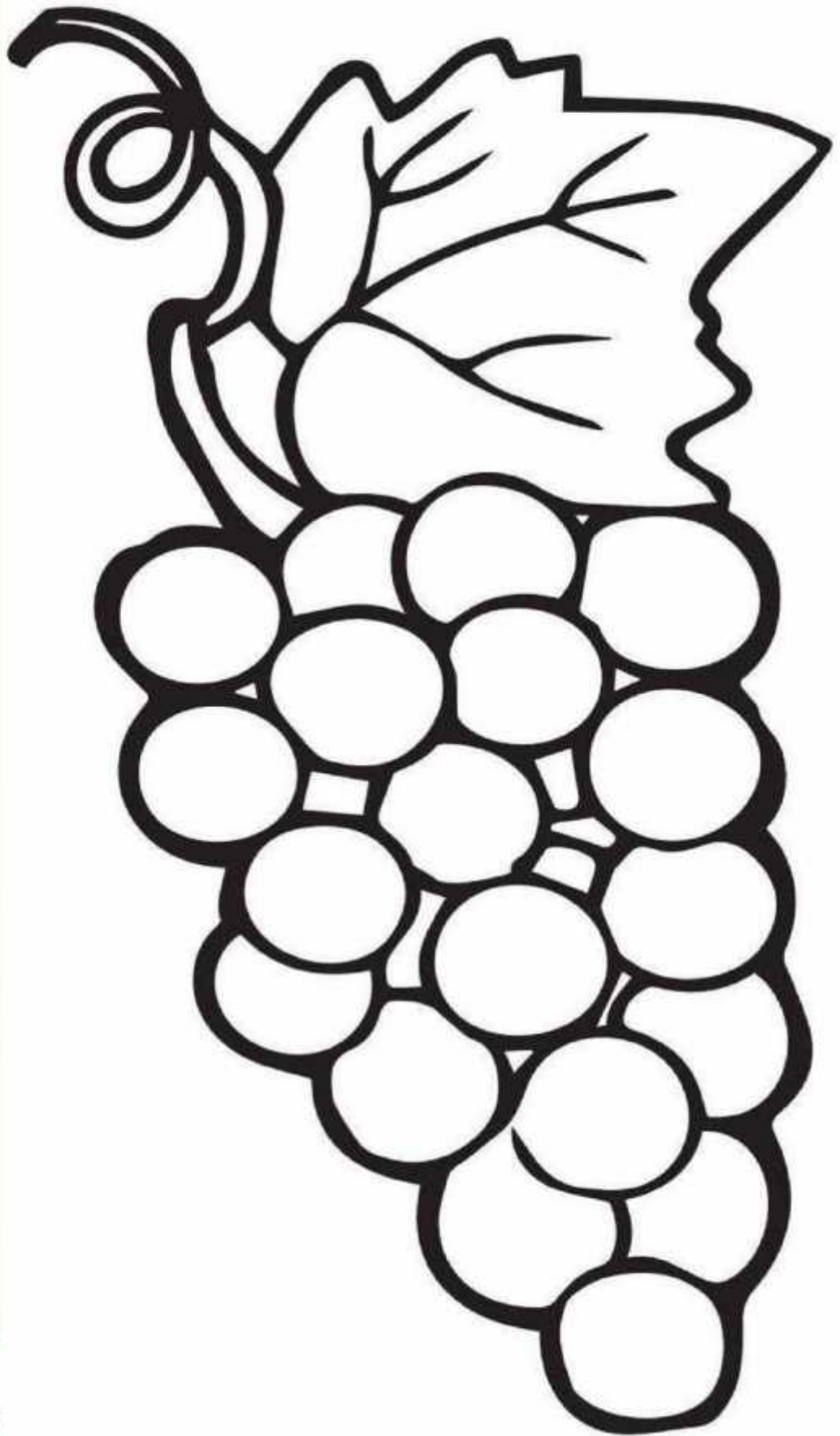

Conjuntos

Agrupar a los patitos de dos en dos.

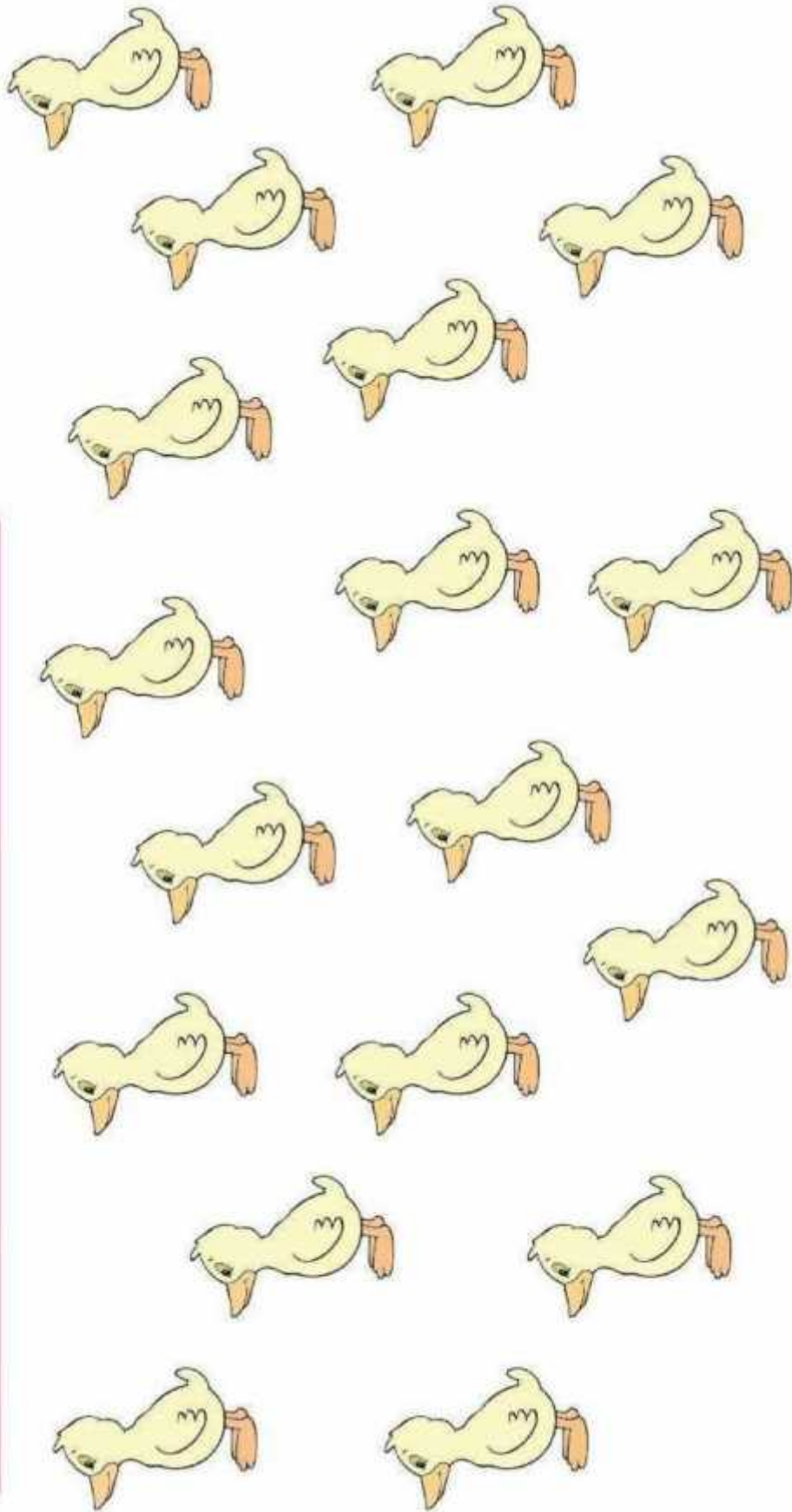

Correspondencias



Une con una flecha cada elemento con la parte del cuerpo que el corresponde.

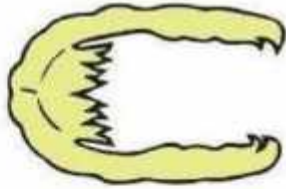

Secuencia por tamaño



Recorta por la líneas y pega de pequeño a grande en la siguiente hoja.

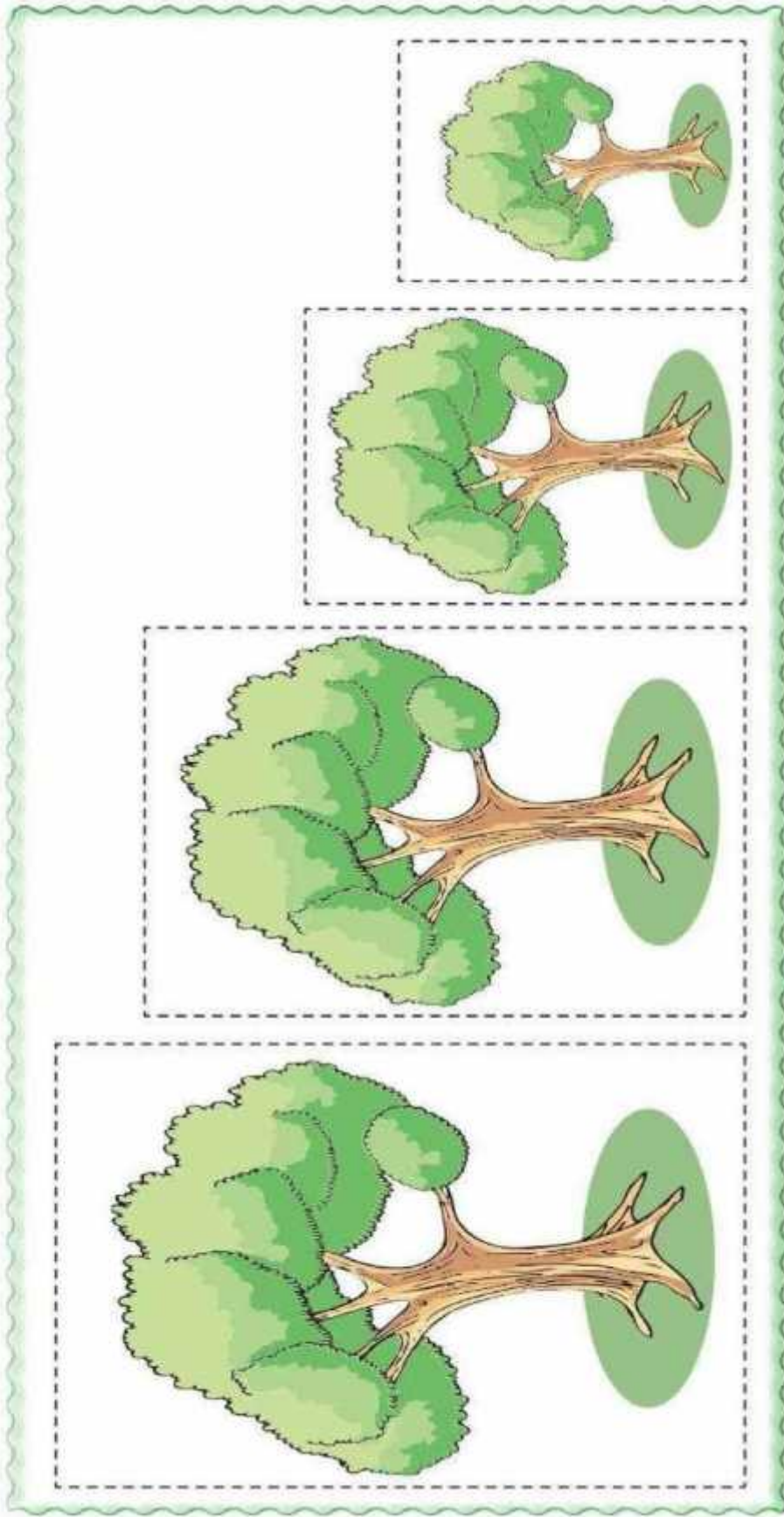



Pega aqui:

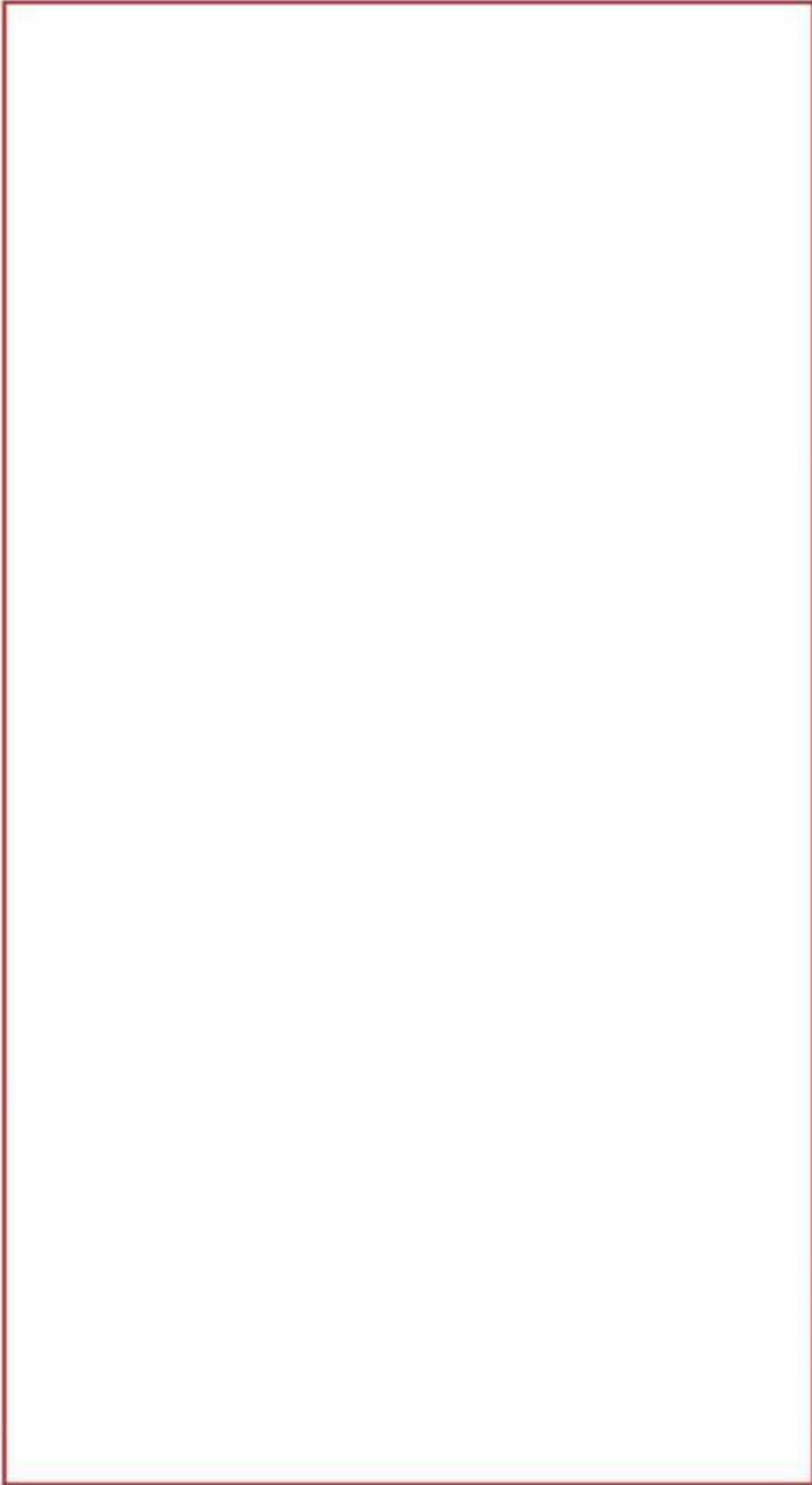

Color negro

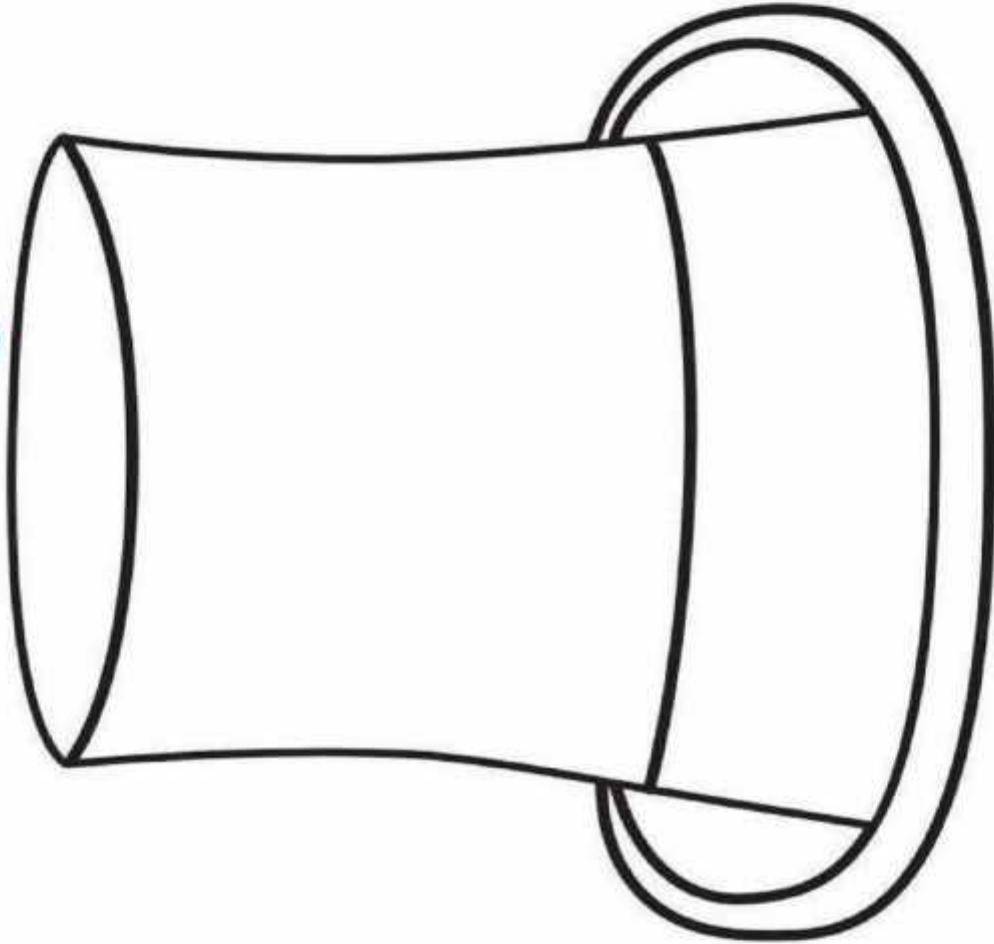

Pinta el sombrero de color negro.



Color negro

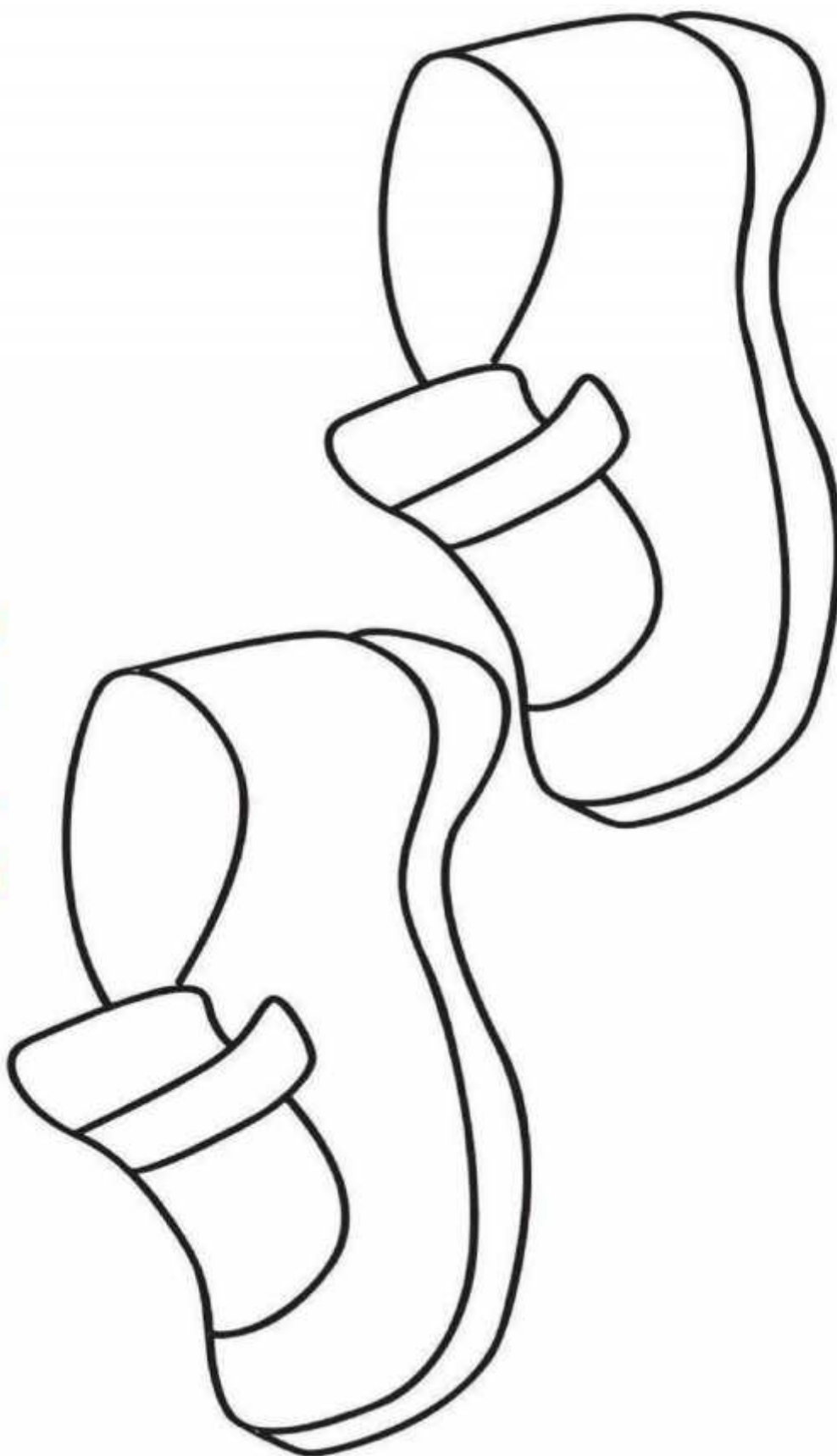

Pinta los zapatos de color negro.

Figuras iguales



Rodea los dibujos que sean iguales a los de la imagen seleccionada.



Figuras incompletas



Que le falta a cada uno de los dos dibujos y complétalos.

